



pompalar  
*pumps*



2026  
Fiyat Listesi-Price List

**NOZBART®**  
*The best of the world...*



**TÜM**

**TÜV  
CERT**  
DIN EN ISO 9001:2015  
Zertifikat 15 100 52993

**TSE**

**EAC**

**CE**

**UHE**  
\* UHE Kurucu Üyesidir.\*

PLASTİK VE MAKİNA KALIP SANAYİ VE TİCARET LİMİTED ŞİRKETİ



**KENDİNDEN EMİŞLİ  
SELF-PRIMING**

**1/4 HP - 1/3 HP - 1/2 HP - 3/4 HP - 1 HP**

**TERMOPLASTİK EKSANTRİK SÜZGEÇLİ SESSİZ SALYANGOZ SANTRİFÜJ POMPALAR  
THERMOPLASTIC CENTRIFUGAL SILENT PUMPS WITH ECCENTRIC PRE-FILTER**



**ÖN FİLTRELİ TERMOPLASTİK SU POMPALARI  
THERMOPLASTIC WATER PUMPS WITH PREFILTER**

HP	MALZEME CİNSİ DESCRIPTION	DEBİ 6 M.M.S FLOW 6 M.W.C	dBA Maks. Verimde at Max. Efficiency	MONOFAZE KOD / CODE	FİYATI (€) PRICE
1/4	Önfiltrerli pompa Pump with prefilter	3 m <sup>3</sup> /saat m <sup>3</sup> /hour	52	PMH-1/4	331
1/3	Önfiltrerli pompa Pump with prefilter	5,5 m <sup>3</sup> /saat m <sup>3</sup> /hour	52	PMH-1/3	345
1/2	Önfiltrerli pompa Pump with prefilter	10 m <sup>3</sup> /saat m <sup>3</sup> /hour	53	PMH-1/2	361
3/4	Önfiltrerli pompa Pump with prefilter	13 m <sup>3</sup> /saat m <sup>3</sup> /hour	55	PMH-3/4	378
1	Önfiltrerli pompa Pump with prefilter	17 m <sup>3</sup> /saat m <sup>3</sup> /hour	57	PMH-1/1	408

⚡ 50 HZ - 2850 d/dak  
rpm

⚡ Elektrik bağlantısı; (1 Faz - 220 V) 50 Hz 2850 devir/dakika  
Electrical Connection; (1 ph -220 V) 50 Hz 2850 rpm

⚡ Diğer voltaj ve frekanslarda pompalar üretilmektedir.  
Special voltages and frequencies are manufactured on request

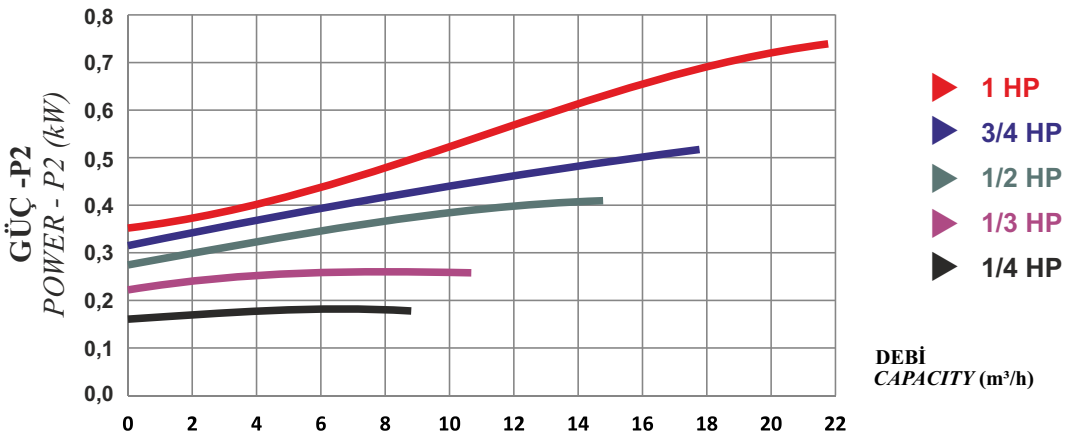
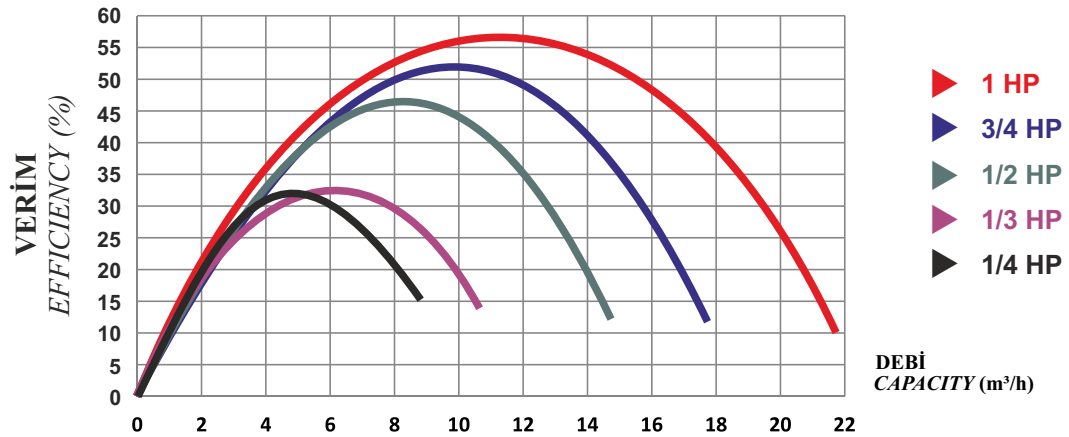
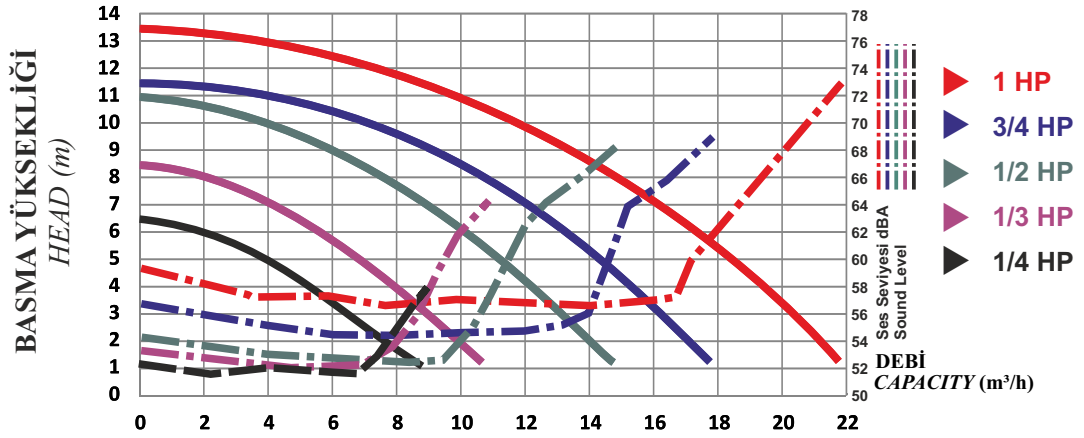

## GERÇEK TEST VERİLERİDİR REAL TEST VALUES

GÜÇ POWER	BASMA YÜKSEKLİĞİ - HEAD (m)					
	2	4	6	8	10	12
	DEBİ - CAPACITY (m³/h)					
1/4 HP	7,5	5,5	2,0			
1/3 HP	9,5	8,0	5,5	2		
1/2 HP	14,0	12,0	10,0	7,5	4,0	
3/4 HP	17,0	15,0	13,0	10,5	7,0	
1 HP	21,0	19,5	17,0	15,0	11,5	7,5

Pompa eğrileri, TSE EN ISO 9906 standartlarına uygundur.  
Pump curves comply with TSE EN ISO 9906 standards.

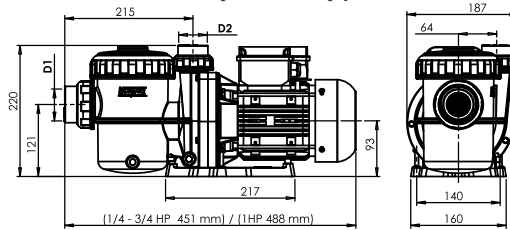

HP	METRIC ISO / DIN		IMPERIAL BS / ANSI / ASTM / AS / NZS			
	D1 mm	D2 mm	D1 inch	D2 mm	D1 inch	D2 mm
1/4	50	40	1 1/2"	48,3	1 1/4"	42,3
1/3	50	40	1 1/2"	48,3	1 1/4"	42,3
1/2	50	40	1 1/2"	48,3	1 1/4"	42,3
3/4	50	40	1 1/2"	48,3	1 1/4"	42,3
1	50	40	1 1/2"	48,3	1 1/4"	42,3

Yoğunluk  
Density

: 1 gr/cm³

Sıcaklık  
Temperature

: 20 °C

Su için geçerli değerlerdir.  
Current values for water.



# ŞİRİN SERİSİ

**KENDİNDEN EMİŞLİ /// SELF-PRIMING****1/2 HP - 3/4 HP - 1 HP****TERMOPLASTİK EKSANTRİK SÜZGEÇLİ SESSİZ SALYANGOZ SANTRİFÜJ POMPALAR**  
**THERMOPLASTIC CENTRIFUGAL SILENT PUMPS WITH ECCENTRIC PRE-FILTER****ÖN FİLTRELİ TERMOPLASTİK SU POMPALARI**  
**THERMOPLASTIC WATER PUMPS WITH PREFILTER**

HP	MALZEME CİNSİ DESCRIPTION	DEBİ 6 M.M.S FLOW 6 M.W.C	dB Maks. Verimde at Max. Efficiency	MONOFAZE KOD / CODE	TRİFAZE KOD / CODE	FİYATI (€)
1/2	Önfiltriteli pompa Pump with prefilter	9,5 m <sup>3</sup> /saat m <sup>3</sup> /hour	54	PMF-1/2	PTF-1/2	455
3/4	Önfiltriteli pompa Pump with prefilter	12,5 m <sup>3</sup> /saat m <sup>3</sup> /hour	56	PMF-3/4	PTF-3/4	468
1	Önfiltriteli pompa Pump with prefilter	21 m <sup>3</sup> /saat m <sup>3</sup> /hour	56	PMF-1/1	PTF-1/1	494

**ÖN FİLTRESİZ TERMOPLASTİK SU POMPALARI**  
**THERMOPLASTIC WATER PUMPS WITHOUT PREFILTER**

HP	MALZEME CİNSİ DESCRIPTION	DEBİ 6 M.M.S FLOW 6 M.W.C	dB Maks. Verimde at Max. Efficiency	MONOFAZE KOD / CODE	TRİFAZE KOD / CODE	FİYATI (€)
1/2	Önfiltrersiz pompa Pump without prefilter	10 m <sup>3</sup> /saat m <sup>3</sup> /hour	54	PM-1/2	PT-1/2	432
3/4	Önfiltrersiz pompa Pump without prefilter	13 m <sup>3</sup> /saat m <sup>3</sup> /hour	56	PM-3/4	PT-3/4	443
1	Önfiltrersiz pompa Pump without prefilter	21,5 m <sup>3</sup> /saat m <sup>3</sup> /hour	56	PM-1/1	PT-1/1	473



## COŞKUN SERİSİ

KENDİNDEN EMİŞLİ /// SELF-PRIMING

1,5 HP - 2 HP - 3 HP

TEKNOLOJİ HARİKASI SÜPER VERİMLİ EKSANTRİK SÜZGEÇLİ  
SESSİZ SALYANGOZ SANTRİFÜJ POMPALARÇOK İŞ AZ ENERJİ  
MORE WORK LESS ENERGYÖN FİLTRELİ TERMOPLASTİK SU POMPALARI  
THERMOPLASTIC WATER PUMPS WITH PREFILTER

HP	MALZEME CİNSİ DESCRIPTION	DEBİ 9 M.M.S FLOW 9 M.W.C	dBA Maks. Verimde at Max. Efficiency	MONOFAZE KOD / CODE	TRİFAZE KOD / CODE	FİYATI (€) PRICE
1,5	Önfiltriteli pompa Pump with prefilter	26,5 m <sup>3</sup> /saat m <sup>3</sup> /hour	59,5	PMF-018	PTF-018	561
2	Önfiltriteli pompa Pump with prefilter	36,5 m <sup>3</sup> /saat m <sup>3</sup> /hour	63,5	PMF-023	PTF-023	656
3	Önfiltriteli pompa Pump with prefilter	48,0 m <sup>3</sup> /saat m <sup>3</sup> /hour	62	PMF-032	PTF-033	721

ÖN FİLTRESİZ TERMOPLASTİK SU POMPALARI  
THERMOPLASTIC WATER PUMPS WITHOUT PREFILTER

HP	MALZEME CİNSİ DESCRIPTION	DEBİ 9 M.M.S FLOW 9 M.W.C	dBA Maks. Verimde at Max. Efficiency	MONOFAZE KOD / CODE	TRİFAZE KOD / CODE	FİYATI (€) PRICE
1,5	Önfiltrersiz pompa Pump without prefilter	27,3 m <sup>3</sup> /saat m <sup>3</sup> /hour	59,5	PM-018	PT-018	527
2	Önfiltrersiz pompa Pump without prefilter	37,6 m <sup>3</sup> /saat m <sup>3</sup> /hour	63,5	PM-023	PT-023	576
3	Önfiltrersiz pompa Pump without prefilter	49,5 m <sup>3</sup> /saat m <sup>3</sup> /hour	62	PM-032	PT-033	623

50 HZ - 2850 d/dak  
rpm

Elektrik bağlantısı; (1 Faz - 220 V) - (3 Faz- D 220 / Y 380 V) 50 Hz 2850 devir/dakika  
Electrical Connection; (1 ph -220 V) - (3 ph- D 220 / Y 380 V) 50 Hz 2850 rpm  
Diğer voltaj ve frekanslarda pompalar üretilmektedir.  
Special voltages and frequencies are manufactured on request.

## 1,5 - 2 - 3 HP PERFORMANS EĞRİLERİ 1,5 - 2 - 3 HP PERFORMANCE RANGE

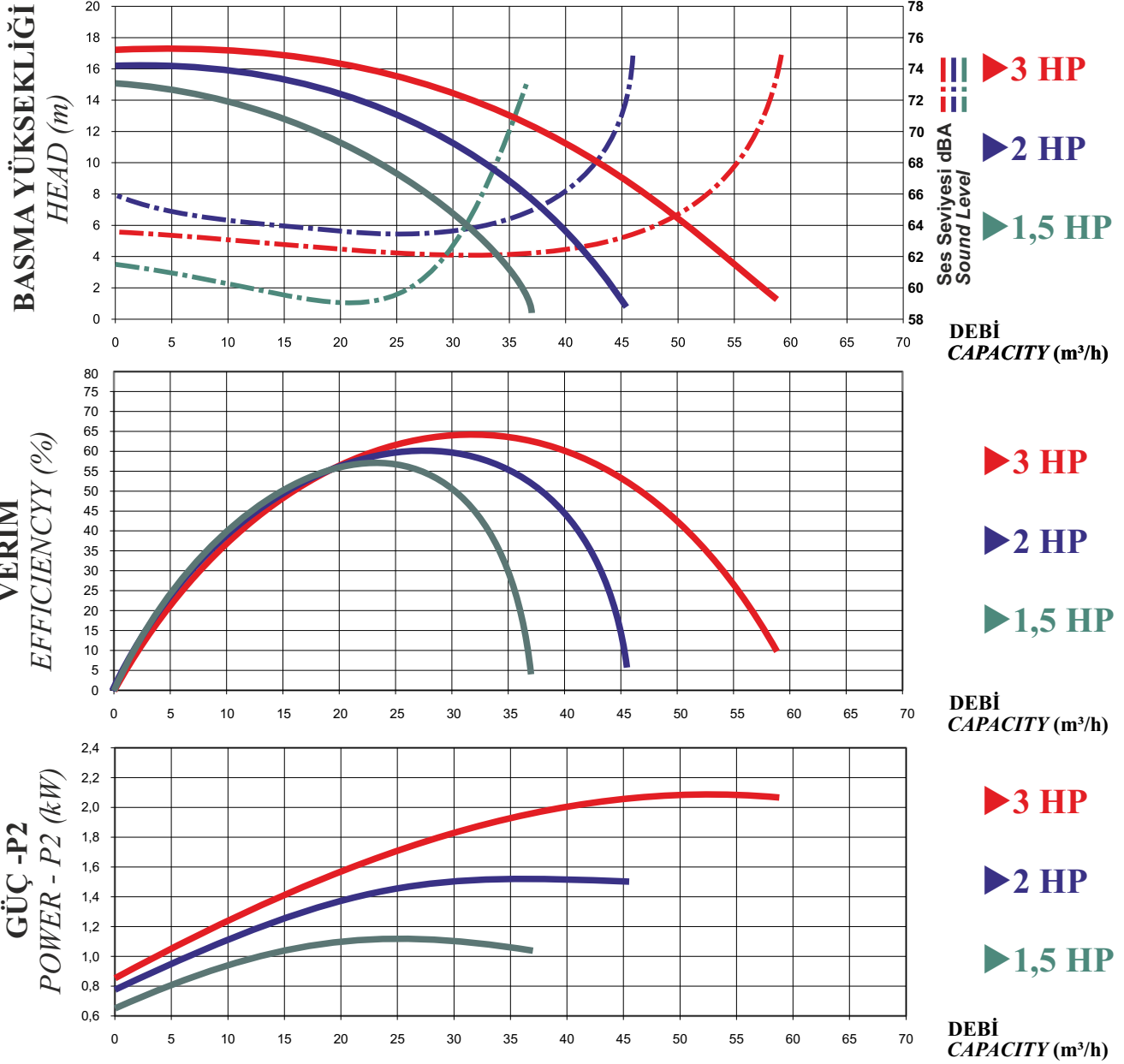

Ön filtresiz pompa eğrileri, TSE EN ISO 9906 standartlarına uygundur.  
Without prefilter pump curves comply with TSE EN ISO 9906 standards.

### GERÇEK TEST VERİLERİDİR REAL TEST VALUES

GÜÇ POWER	BASMA YÜKSEKLİĞİ - HEAD (m)						
	4	6	8	10	12	14	16
1,5 HP	34,0	31,0	28,0	23,5	18,0	9,5	
2 HP	42,0	39,5	36,5	33,0	28,0	22,0	
3 HP	54,0	51,0	47,0	43,0	38,0	32,0	22,0

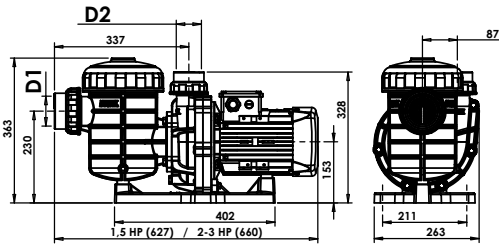

HP	METRIC ISO / DIN		IMPERIAL BS / ANSI / ASTM / AS / NZS			
	D1 mm	D2 mm	D1		D2	
1,5	63	50	2"	60,3	1½"	48,3
2	75	63	2 ½"	75,3	2"	60,3
3	75	63	2 ½"	75,3	2"	60,3

Özgül Ağırlık : 1 gr/cm³ Sıcaklık : 20 °C Su için geçerli değerlerdir.  
Specific Gravity Temperature Current values for water.

## İLK SERİ

KENDİNDEN EMİŞLİ /// SELF-PRIMING

1 HP - 1,5 HP - 2 HP - 3 HP

ÖN FİLTRELİ TERMOPLASTİK SU POMPALARI  
THERMOPLASTIC WATER PUMPS WITH PREFILTER

HP	MALZEME CİNSİ DESCRIPTION	DEBİ 9 M.M.S FLOW 9 M.W.C	dB Maks. Verimde at Max. Efficiency	MONOFAZE KOD / CODE	TRİFAZE KOD / CODE	FİYATI (€)
1	Önfiltriteli pompa Pump with prefilter	17 m <sup>3</sup> /saat m <sup>3</sup> /hour	64,5	PMF-010	PTF-010	519
1,5	Önfiltriteli pompa Pump with prefilter	21 m <sup>3</sup> /saat m <sup>3</sup> /hour	65	PMF-015	PTF-015	561
2	Önfiltriteli pompa Pump with prefilter	24,5 m <sup>3</sup> /saat m <sup>3</sup> /hour	64	PMF-020	PTF-020	656
3	Önfiltriteli pompa Pump with prefilter	32 m <sup>3</sup> /saat m <sup>3</sup> /hour	68	PMF-030	PTF-030	721

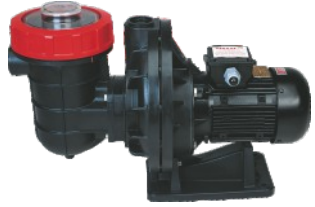
ÖN FİLTRESİZ TERMOPLASTİK SU POMPALARI  
THERMOPLASTIC WATER PUMPS WITHOUT PREFILTER

HP	MALZEME CİNSİ DESCRIPTION	DEBİ 9 M.M.S FLOW 9 M.W.C	dB Maks. Verimde at Max. Efficiency	MONOFAZE KOD / CODE	TRİFAZE KOD / CODE	FİYATI (€)
1	Önfiltrersiz pompa Pump without prefilter	17 m <sup>3</sup> /saat m <sup>3</sup> /hour	64,5	PM-010	PT-010	468
1,5	Önfiltrersiz pompa Pump without prefilter	21 m <sup>3</sup> /saat m <sup>3</sup> /hour	65	PM-015	PT-015	527
2	Önfiltrersiz pompa Pump without prefilter	24,5 m <sup>3</sup> /saat m <sup>3</sup> /hour	64	PM-020	PT-020	576
3	Önfiltrersiz pompa Pump without prefilter	32 m <sup>3</sup> /saat m <sup>3</sup> /hour	68	PM-030	PT-030	623



⚡ 50 HZ - 2850 d/dak  
rpm

⚡ Elektrik bağlantısı; (1 Faz - 220 V) - (3 Faz- D 220 / Y 380 V) 50 Hz 2850 devir/dakika  
Electrical Connection; (1 ph -220 V) - (3 ph- D 220 / Y 380 V) 50 Hz 2850 rpm  
⚡ Diğer voltaj ve frekanslarda pompalar üretilmektedir.  
Special voltages and frequencies are manufactured on request.

## 1- 1,5 - 2 - 3 HP PERFORMANS EĞRİLERİ 1- 1,5 - 2 - 3 HP PERFORMANCE RANGE

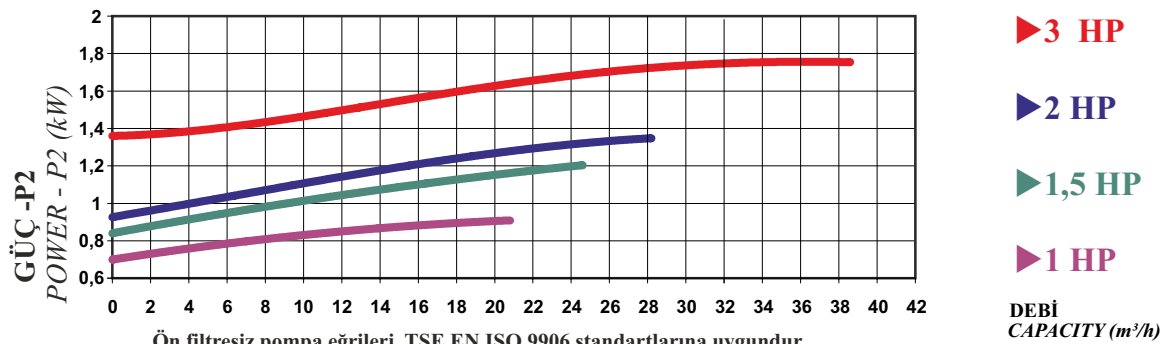
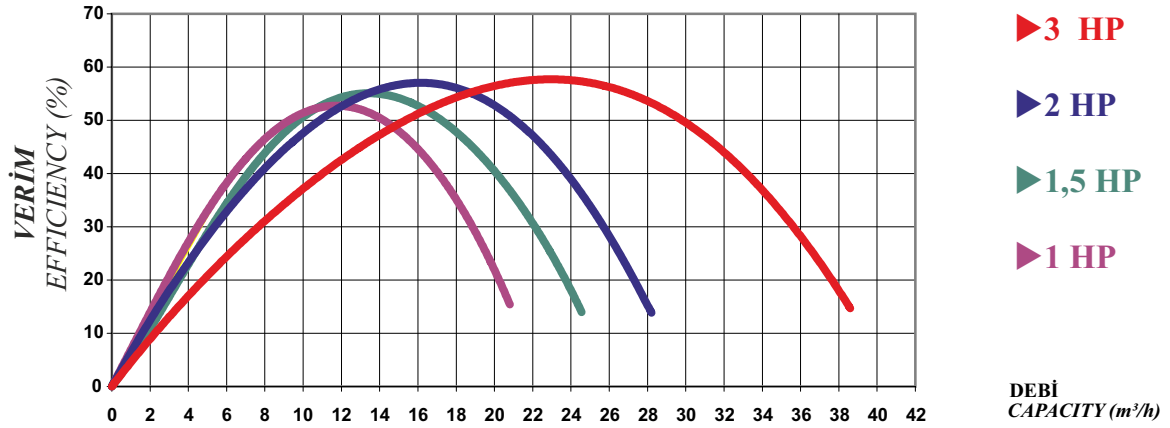
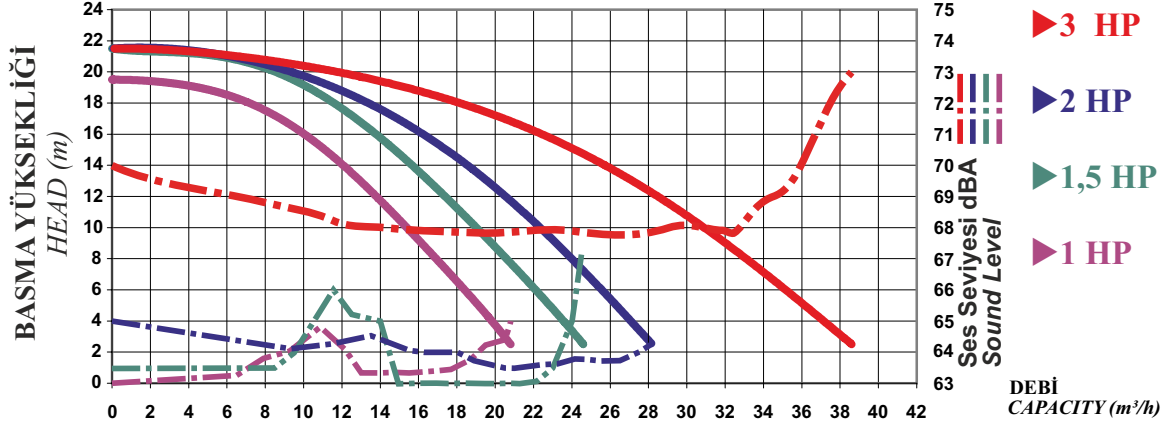

Ön filtresiz pompa eğrileri, TSE EN ISO 9906 standartlarına uygundur.  
Without prefilter pump curves comply with TSE EN ISO 9906 standards.

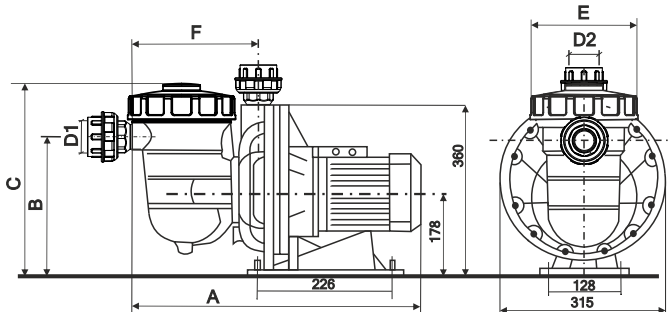

### GERÇEK TEST VERİLERİ REAL TEST VALUES

GÜÇ POWER	BASMA YÜK. - HEAD (m)							
	6	8	10	12	14	16	18	20
1 HP	19	17	15	14	12	10	7	
1,5 HP	22	21	19	17	16	14	11	8
2 HP	25	24	23	21	19	17	13	10
3 HP	35	33	31	29	26	23	18	12

Özgül Ağırlık  
Specific Gravity : 1 gr/cm³

Sıcaklık  
Temperature : 20 °C

Akışkan için geçerli değerlerdir.  
Current values for fluid

POMPA PUMP	A mm	B mm	C mm	F mm	E mm	D1 mm	D2 mm	D1 Ansi	D2 Ansi
1 HP - 1,5 HP	616	280	385	242	203	63	50	2"	1 1/2"
2 HP - 3 HP	650	292	415	276	230	75	63	2 1/2"	2"

## HUZUR SERİSİ

MÜTHİŞ DEBİ - KENDİNDEN EMİŞLİ  
GREAT FLOW - SELF PRIMING

**SÜPER SESSİZ**  
PERFECTLY SILENT

**SÜPER VERİMLİ**  
EXCELLENTLY EFFICIENT

1,5 HP - 2 HP - 3 HP

TERMOPLASTİK EKSANTRİK SÜZGEÇLİ SESSİZ SALYANGOZ SANTRİFÜJ POMPALAR  
THERMOPLASTIC CENTRIFUGAL SILENT PUMPS WITH ECCENTRIC PRE-FILTER

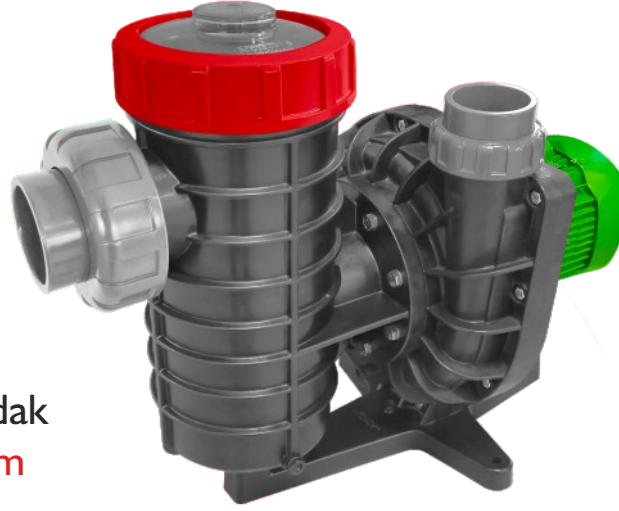

**1450** d/dak  
rpm



### ÖN FİLTRELİ TERMOPLASTİK SU POMPALARI THERMOPLASTIC WATER PUMPS WITH PREFILTER



HP	MALZEME CİNSİ DESCRIPTION	DEBİ 9 M.S.S FLOW 9 M.W.C	dBA Maks. Verimde at Max. Efficiency	Monofaze Kod / Code	Trifaze Kod / Code	FİYATI (€) PRICE
1.5	Önfiltrli pompa Pump with prefilter	25 m <sup>3</sup> /saat m <sup>3</sup> /hour	66	PMF-017	PTF-017	931
2	Önfiltrli pompa Pump with prefilter	38 m <sup>3</sup> /saat m <sup>3</sup> /hour	57	PMF-022	PTF-022	999
3	Önfiltrli pompa Pump with prefilter	53 m <sup>3</sup> /saat m <sup>3</sup> /hour	59	-	PTF-032	1.031

### ÖN FİLTRESİZ TERMOPLASTİK SU POMPALARI THERMOPLASTIC WATER PUMPS WITHOUT PREFILTER



HP	MALZEME CİNSİ DESCRIPTION	DEBİ 9 M.S.S FLOW 9 M.W.C	dBA Maks. Verimde at Max. Efficiency	Monofaze Kod / Code	Trifaze Kod / Code	FİYATI (€) PRICE
1.5	Önfiltrsiz pompa Pump without prefilter	25,8 m <sup>3</sup> /saat m <sup>3</sup> /hour	66	PM-017	PT-017	781
2	Önfiltrsiz pompa Pump without prefilter	39,2 m <sup>3</sup> /saat m <sup>3</sup> /hour	57	PM-022	PT-022	849
3	Önfiltrsiz pompa Pump without prefilter	54,6 m <sup>3</sup> /saat m <sup>3</sup> /hour	59	-	PT-032	882

⚡ 50 HZ - 1450 d/dak  
rpm

⚡ Elektrik bağlantısı; (1 Faz - 220 V) - (3 Faz- D 220 / Y 380 V) 50 Hz 1450 devir/dakika  
Electrical Connection; (1 ph -220 V) - (3 ph- D 220 / Y 380 V) 50 Hz 1450 rpm  
⚡ Diğer voltaj ve frekanslar üretilmektedir.  
Special voltages and frequencies are manufactured on request.

## SÜPER SESSİZ 1,5 - 2 - 3 HP PERFORMANS EĞRİLERİ PERFECTLY SILENT 1,5 - 2 - 3 HP PERFORMANCE RANGE

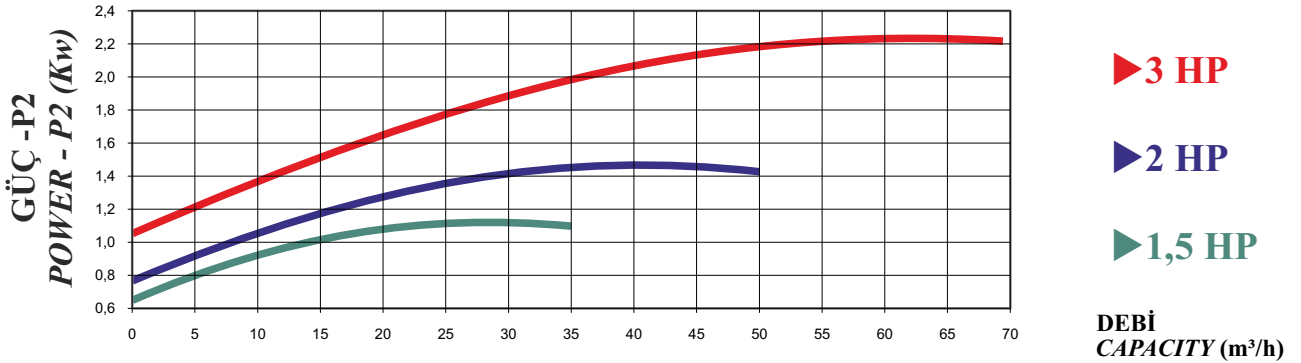
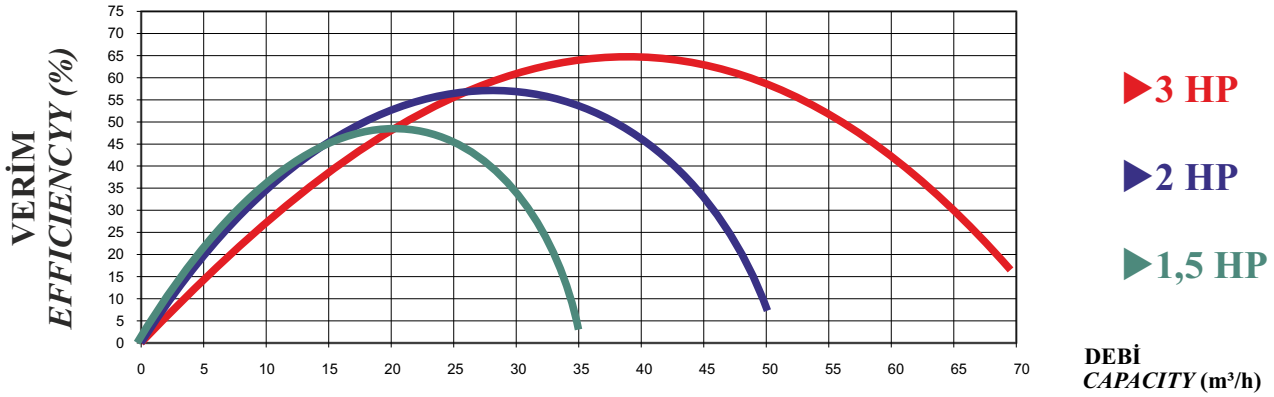
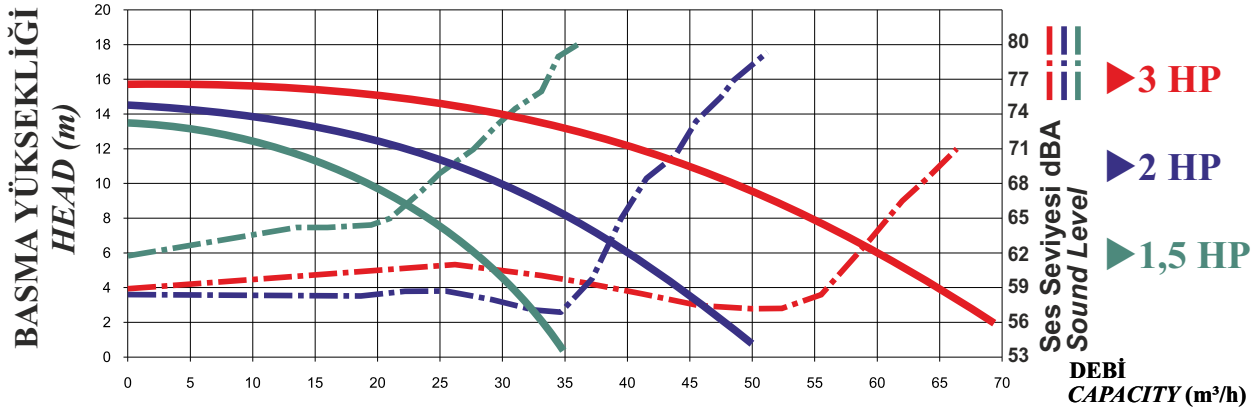

Ön filtresiz pompa eğrileri, TSE EN ISO 9906 standartlarına uygundur.  
Without prefilter pump curves comply with TSE EN ISO 9906 standards.

### GERÇEK TEST VERİLERİDİR REAL TEST VALUES

GÜÇ POWER	BASMA YÜKSEKLİĞİ - HEAD (m)					
	4	6	8	10	12	14
	DEBİ - CAPACITY (m³/h)					
1,5 HP	31	28	24	19	12,5	
2 HP	44	40	38,5	30	22,5	8,5
3 HP	65	60	54,5	48,5	41	30

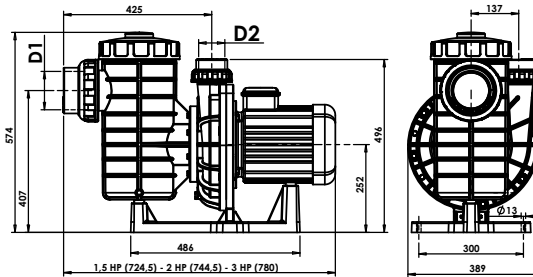

HP	METRIC ISO / DIN		IMPERIAL BS / ANSI / ASTM / AS / NZS			
	D1 mm	D2 mm	D1		D2	
	inch	mm	inch	mm	inch	mm
1,5	90	75	3"	88,9	2 1/2"	75,3
2	90	75	3"	88,9	2 1/2"	75,3
3	90	75	3"	88,9	2 1/2"	75,3

Özgül Ağırlık  
Specific Gravity

: 1 gr/cm³

Sıcaklık  
Temperature

: 20 °C

Su için geçerli değerlerdir.  
Current values for water.

# SÜPER TAŞKIN SERİSİ

3,5 HP - 4,5 HP -5,5 HP

NOZBART KENDİNDEN EMİŞLİ EKSANTRİK SÜZGEÇLİ **TRİFAZE** TERMOPLASTİK SU POMPALARI  
**NOZBART SELF-PRIMING TRIPHASE THERMOPLASTIC WATER PUMPS WITH ECCENTRIC FILTER**



**2850** d/dak  
rpm



NOZBART ÖNFİLTRELİ **TRİFAZE** TERMOPLASTİK SU POMPALARI  
**NOZBART TRIPHASE THERMOPLASTIC WATER PUMPS WITH PREFILTER**



MALZEME CİNSİ DESCRIPTION	DEBİ 9 M.S.S FLOW 9 M.W.C	dBA Maks. Verimde at Max. Efficiency	CODE KOD	FİYAT (€) PRICE	AĞIRLIK WEIGHT
3,5 HP Önfiltreli su pompası 3.5 HP pump with prefilter	64 m <sup>3</sup> /saat m <sup>3</sup> /hour	63	PTF-035S	1.228	29.600 gr.
4,5 HP Önfiltreli su pompası 4.5 HP pump with prefilter	73 m <sup>3</sup> /saat m <sup>3</sup> /hour	69	PTF-045S	1.296	35.600 gr.
5,5 HP Önfiltreli su pompası 5.5 HP pump with prefilter	80 m <sup>3</sup> /saat m <sup>3</sup> /hour	72	PTF-055S	1.352	35.700 gr.

NOZBART ÖNFİLTRESİZ **TRİFAZE** TERMOPLASTİK SU POMPALARI  
**NOZBART TRIPHASE THERMOPLASTIC WATER PUMPS WITHOUT PREFILTER**



MALZEME CİNSİ DESCRIPTION	DEBİ 9 M.S.S FLOW 9 M.W.C	dBA Maks. Verimde at Max. Efficiency	CODE KOD	FİYAT (€) PRICE	AĞIRLIK WEIGHT
3,5 HP Önfiltresiz su pompası 3.5 HP Pump without prefilter	66 m <sup>3</sup> /saat m <sup>3</sup> /hour	63	PT-035S	1.078	26.400 gr.
4,5 HP Önfiltresiz su pompası 4.5 HP Pump without prefilter	75 m <sup>3</sup> /saat m <sup>3</sup> /hour	69	PT-045S	1.146	29.600 gr.
5,5 HP Önfiltresiz su pompası 5.5 HP Pump without prefilter	82 m <sup>3</sup> /saat m <sup>3</sup> /hour	72	PT-055S	1.200	29.700 gr.

⚡ 50 HZ - 2850 d/dak  
rpm

- ⚡ Elektrik bağlantısı; (3 Faz- D 220 / Y 380 V) 50 Hz 2850 devir/dakika  
Electrical Connection; (3 ph- D 220 / Y 380 V) 50 Hz 2850 rpm
- ⚡ Y Bağlantı  
Y Connection
- ⚡ Diğer voltaj ve frekanslarda pompalar üretilmektedir.  
Special voltages and frequencies are manufactured on request.

### 3,5 - 4,5 - 5,5 HP PERFORMANS EĞRİLERİ 3,5 - 4,5 - 5,5 HP PERFORMANCE RANGE

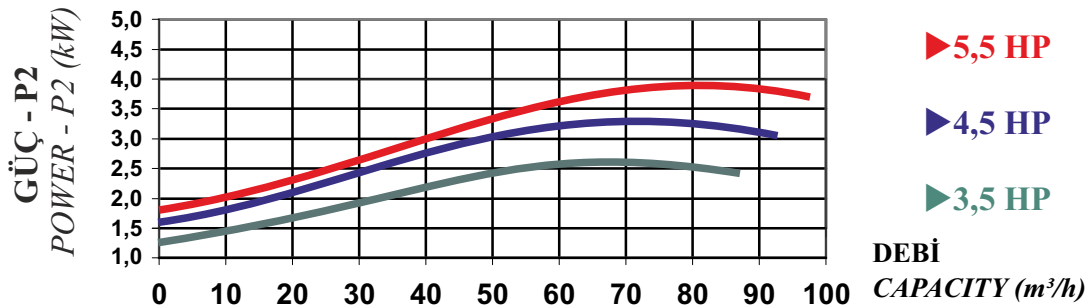
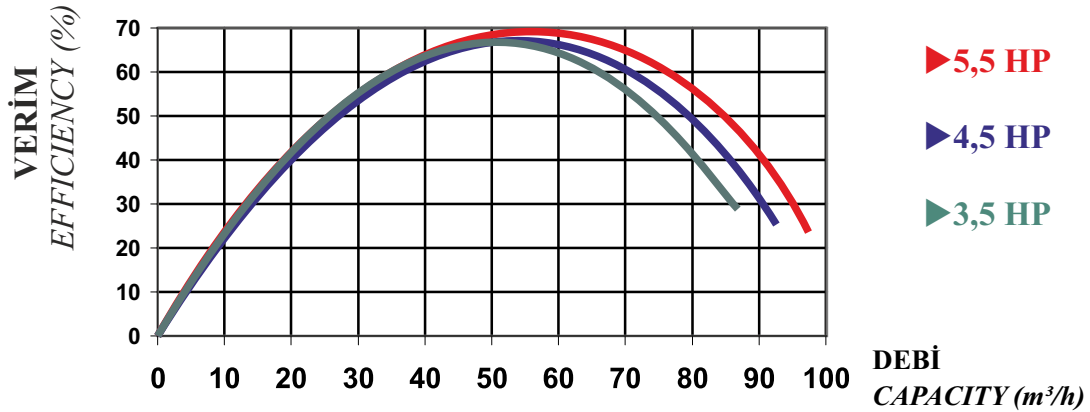
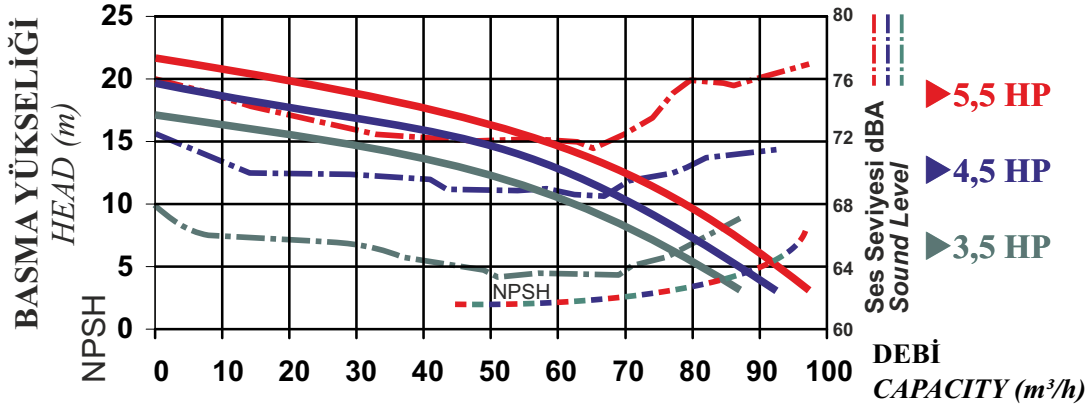

Ön filtresiz pompa eğrileri, TSE EN ISO 9906 standartlarına uygundur.  
Without prefilter pump curves comply with TSE EN ISO 9906 standards.

### GERÇEK TEST VERİLERİ REAL TEST VALUES

GÜÇ POWER	BASMA YÜKSEKLİĞİ - HEAD (m)							
	6	8	10	12	14	16	18	20
3,5 HP	78	70	62	52	36	16	-	-
4,5 HP	84	78	72	64	54	40	20	-
5,5 HP	90	85	78	72	64	52	38	20

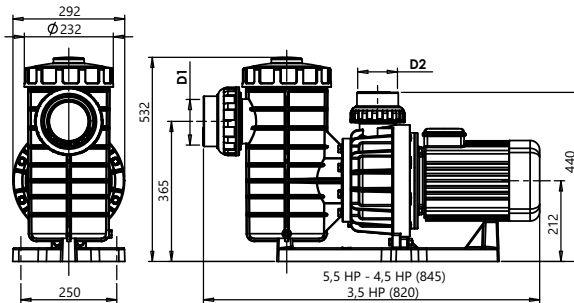

HP	METRIC ISO / DIN		IMPERIAL BS / ANSI / ASTM / AS / NZS	
	D1 mm	D2 mm	D1 inch	D2 inch
3,5	110	90	4"	3"
4,5	110	90	4"	3"
5,5	110	90	4"	3"

Özgül Ağırlık : 1 gr/cm³ Sıcaklık : 20 °C Su için geçerli değerlerdir.  
Specific Gravity : 1 gr/cm³ Temperature : 20 °C Current values for water.



# SÜPER TUFAN SERİSİ

7,5 HP - 10 HP -12,5 HP

NOZBART KENDİNDEN EMİŞLİ EKSANTRİK SÜZGEÇLİ **TRİFAZE** TERMOPLASTİK SU POMPALARI  
**NOZBART SELF-PRIMING TRIPHASE THERMOPLASTIC WATER PUMPS WITH ECCENTRIC FILTER**



**2850** d/dak  
rpm



NOZBART ÖNFİLTRELİ **TRİFAZE** TERMOPLASTİK SU POMPALARI  
**NOZBART TRIPHASE THERMOPLASTIC WATER PUMPS WITH PREFILTER**



MALZEME CİNSİ DESCRIPTION	DEBİ 9 M.S.S FLOW 9 M.W.C	dBA Maks. Verimde at Max. Efficiency	KOD CODE	FİYATI (€) PRICE (€)
7,5 HP Önfiltreli su pompası 7.5 HP Pump with prefilter	125 m <sup>3</sup> /saat m <sup>3</sup> /hour	74	PTF-075S	1.780
10 HP Önfiltreli su pompası 10 HP Pump with prefilter	150 m <sup>3</sup> /saat m <sup>3</sup> /hour	75	PTF-100S	2.106
12,5 HP Önfiltreli su pompası 12.5 HP Pump with prefilter	160 m <sup>3</sup> /saat m <sup>3</sup> /hour		PTF-125S	2.813

NOZBART ÖNFİLTRESİZ **TRİFAZE** TERMOPLASTİK SU POMPALARI  
**NOZBART TRIPHASE THERMOPLASTIC WATER PUMPS WITHOUT PREFILTER**



MALZEME CİNSİ DESCRIPTION	DEBİ 9 M.S.S FLOW 9 M.W.C	dBA Maks. Verimde at Max. Efficiency	KOD CODE	FİYATI (€) PRICE (€)
7,5 HP Önfiltresiz su pompası 7.5 HP Pump without prefilter	130 m <sup>3</sup> /saat m <sup>3</sup> /hour	74	PT-075S	1.636
10 HP Önfiltresiz su pompası 10 HP Pump without prefilter	155 m <sup>3</sup> /saat m <sup>3</sup> /hour	75	PT-100S	1.955
12,5 HP Önfiltresiz su pompası 12.5 HP Pump without prefilter	170 m <sup>3</sup> /saat m <sup>3</sup> /hour		PT-125S	2.663

⚡ **50 HZ - 2850 d/dak**  
**rpm**

- ⚡ Elektrik bağlantısı; (3 Faz- D 400 / Y 690 V) 50 Hz 2850 devir/dakika  
*Electrical Connection; (3 ph- D 400 / Y 690 V) 50 Hz 2850 rpm*
- ⚡ Y / D - Bağlantı (3 Sn Y çalışacak sonra D'e geçecek)  
*Y / D - Connection (3 Sec. work Y then go to D)*
- ⚡ Diğer voltaj ve frekanslarda pompalar üretilmektedir.  
*Special voltages and frequencies are manufactured on request.*

## 7,5 - 10 - 12,5 HP PERFORMANS EĞRİLERİ 7,5 - 10 - 12,5 HP PERFORMANCE RANGE

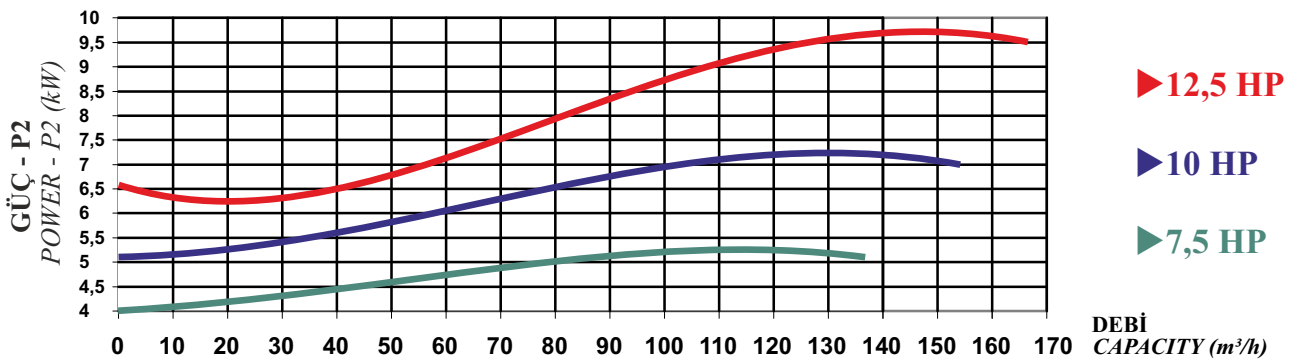
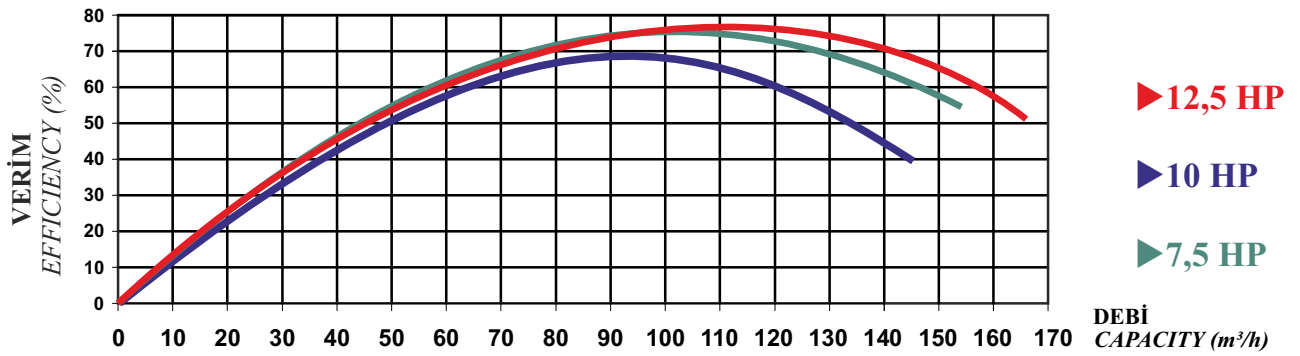
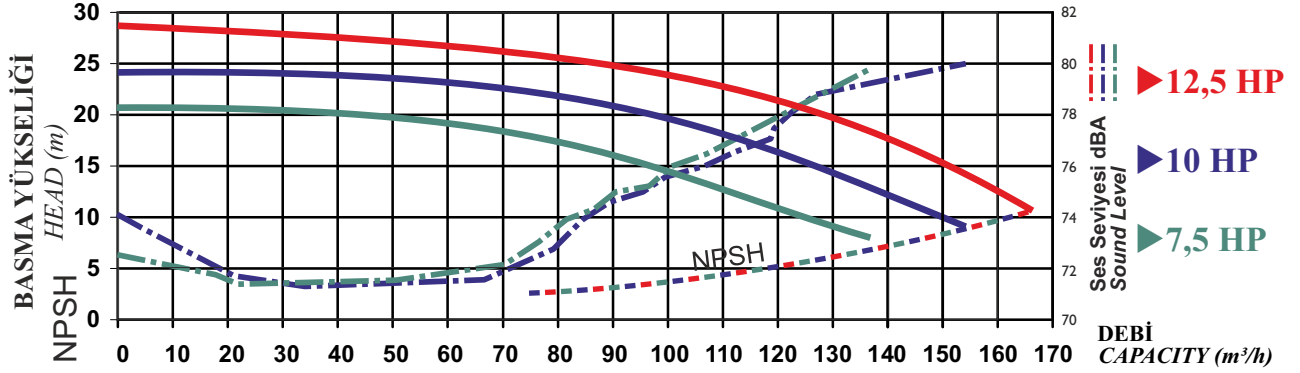

Ön filtresiz pompa eğrileri, TSE EN ISO 9906 standartlarına uygundur.  
Without prefilter pump curves comply with TSE EN ISO 9906 standards.

### GERÇEK TEST VERİLERİ REAL TEST VALUES

GÜÇ POWER	BASMA YÜKSELİĞİ - HEAD (m)								
	10	12	14	16	18	20	22	24	26
7,5 HP	125	115	100	90	75	45	-	-	-
10 HP	150	140	130	120	110	95	75	-	-
12,5 HP	165	160	155	145	140	125	115	100	75

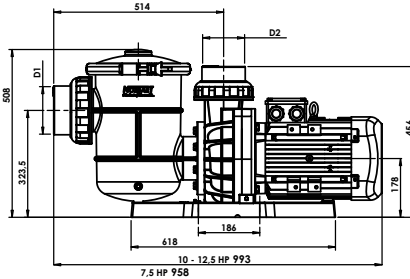
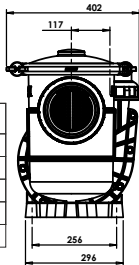

HP	METRIC ISO / DIN		IMPERIAL BS / ANSI / ASTM / AS / NZS	
	D1 mm	D2 mm	D1 inch	D2 inch
7,5	110	110	4"	4"
10	125	110	4"	4"
12,5	125	110	4"	4"

Özgül Ağırlık  
Specific Gravity : 1 gr/cm³

Sıcaklık  
Temperature : 20 °C

Su için geçerli değerlerdir.  
Current values for water.

# TSUNAMI SERİSİ

15 HP - 20 HP - 25 HP - 30 HP

## DÜNYADA İLK

SÜPER SESSİZ - SÜPER VERİMLİ MÜTHİŞ DEBİ - KENDİNDEN EMİŞLİ

PERFECTLY SILENT - EXCELLENT EFFICIENCY-GREAT FLOW - SELF PRIMING

TERMOPLASTİK, EKSANTRİK SÜZGEÇLİ, SALYANGOZ SANTRİFÜJ POMPALAR  
THERMOPLASTIC CENTRIFUGAL SILENT PUMPS WITH ECCENTRIC PRE-FILTER

1450 d/dak  
rpm



EKSANTRİK SÜZGEÇ  
ECCENTRIC PRE-FILTER



SÜPER MUKAVEMETLİ  
TERMOPLASTİK ÇARK  
SUPER-STRENGTH THERMOPLASTIC IMPELLER

### ÖN FİLTRELİ TERMOPLASTİK SU POMPALARI

#### THERMOPLASTIC WATER PUMPS WITH PREFILTER

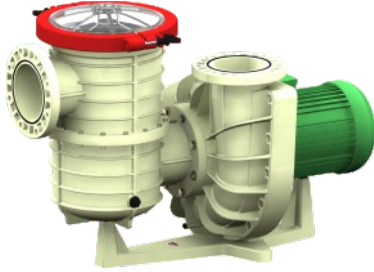

HP	MALZEME CİNSİ DESCRIPTION	DEBİ 9 M.S.S FLOW 9 M.W.C	Trifaze Kod / Code	FİYATI (€)
15	80 lt Önfiltrli pompa Pump with prefilter (80 lt)	255 m <sup>3</sup> /saat m <sup>3</sup> /hour	PTF-150	6.003
20	80 lt Önfiltrli pompa Pump with prefilter (80 lt)	325 m <sup>3</sup> /saat m <sup>3</sup> /hour	PTF-200	6.667
25	80 lt Önfiltrli pompa Pump with prefilter (80 lt)	375 m <sup>3</sup> /saat m <sup>3</sup> /hour	PTF-250	7.141
30	80 lt Önfiltrli pompa Pump with prefilter (80 lt)	435 m <sup>3</sup> /saat m <sup>3</sup> /hour	PTF-300	7.890

### ÖN FİLTRESİZ TERMOPLASTİK SU POMPALARI

#### THERMOPLASTIC WATER PUMPS WITHOUT PREFILTER

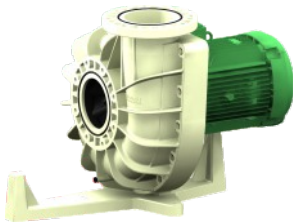

HP	MALZEME CİNSİ DESCRIPTION	DEBİ 9 M.S.S FLOW 9 M.W.C	Trifaze Kod / Code	FİYATI (€)
15	Önfiltrsiz pompa Pump without prefilter	265 m <sup>3</sup> /saat m <sup>3</sup> /hour	PT-150	5.152
20	Önfiltrsiz pompa Pump without prefilter	335 m <sup>3</sup> /saat m <sup>3</sup> /hour	PT-200	5.816
25	Önfiltrsiz pompa Pump without prefilter	385 m <sup>3</sup> /saat m <sup>3</sup> /hour	PT-250	6.290
30	Önfiltrsiz pompa Pump without prefilter	445 m <sup>3</sup> /saat m <sup>3</sup> /hour	PT-300	7.040

⚡ 50 HZ - 1450 d/dak.  
rpm

- ⚡ Elektrik bağlantısı; (3 Faz- D 400 / Y 690 V) 50 Hz 1450 devir/dakika  
Electrical Connection; (3 ph- D 400 / Y 690 V) 50 Hz 1450 rpm
- ⚡ Y / D - Bağlantı (3 Sn Y çalışacak sonra D'e geçecek)  
Y / D - Connection (3 Sec. work Y then go to D)
- ⚡ Diğer voltaj ve frekanslarda pompalar üretilmektedir.  
Special voltages and frequencies are manufactured on request.

## SÜPER SESSİZ 15 - 20 - 25 - 30 HP PERFORMANS EĞRİLERİ PERFECTLY SILENT 15 - 20 - 25 - 30 HP PERFORMANCE RANGE

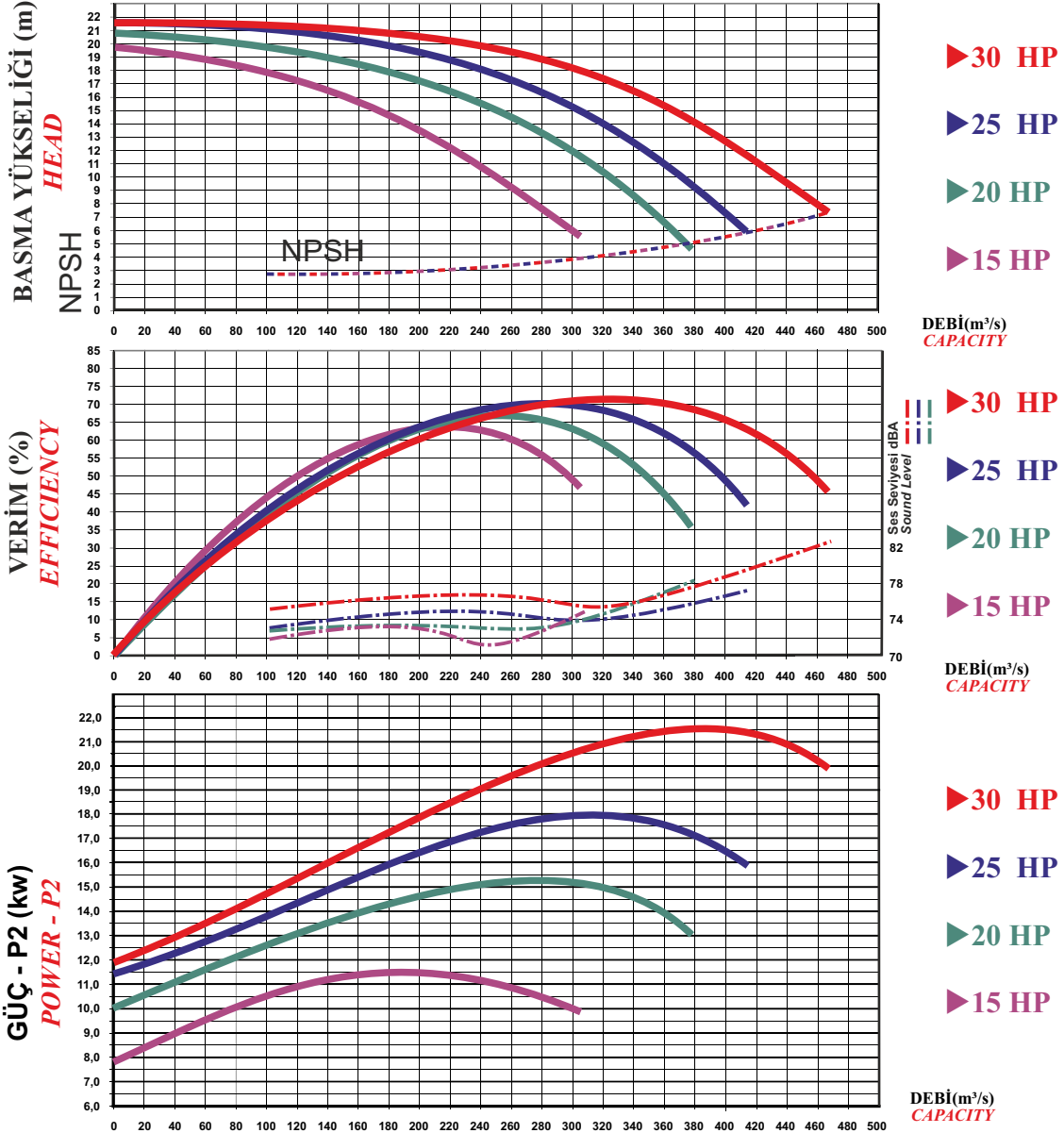

Ön filtresiz pompa eğrileri, TSE EN ISO 9906 standartlarına uygundur.  
Without prefilter pump curves comply with TSE EN ISO 9906 standards.

### GERÇEK TEST VERİLERİDİR REAL TEST VALUES

GÜÇ POWER	BASMA YÜKSEKLİĞİ - HEAD (m)						
	8	10	12	14	16	18	20
15 HP	275	250	225	192	150	95	
20 HP	345	325	300	270	230	175	85
25 HP	395	370	350	320	287	240	172
30 HP	460	430	410	380	350	300	230

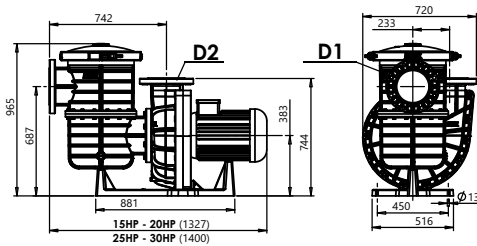

HP	METRIC ISO / DIN		IMPERIAL BS / ANSI / ASTM / AS / NZS	
	D1 / D2	mm	D1 / D2	inch
15	225	8"	219,4	8"
20	225	8"	219,4	8"
25	225	8"	219,4	8"
30	225	8"	219,4	8"

Özgül Ağırlık : 1 gr/cm<sup>3</sup> Sıcaklık : 20 °C Su için geçerli değerlerdir.  
Specific Gravity : 1 gr/cm<sup>3</sup> Temperature : 20 °C Current values for water.

# SULTAN SERİSİ

## 40 HP - 50 HP - 60 HP

# DÜNYADA İLK

SÜPER SESSİZ - SÜPER VERİMLİ MÜTHİŞ DEBİ - KENDİNDEN EMİŞLİ

*PERFECTLY SILENT - EXCELLENT EFFICIENCY-GREAT FLOW - SELF PRIMING*

TERMOPLASTİK, EKSANTRİK SÜZGEÇLİ, SALYANGOZ SANTRİFÜJ POMPALAR

*THERMOPLASTIC CENTRIFUGAL SILENT PUMPS WITH ECCENTRIC PRE-FILTER*

**1450** d/dak  
rpm



EKSANTRİK SÜZGEÇ  
ECCENTRIC PRE-FILTER



SÜPER MUKAVEMETLİ  
TERMOPLASTİK ÇARK  
SUPER-STRENGTH THERMOPLASTIC IMPELLER

### ÖN FİLTRELİ TERMOPLASTİK SU POMPALARI THERMOPLASTIC WATER PUMPS WITH PREFILTER

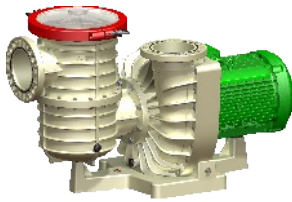

HP	MALZEME CİNSİ DESCRIPTION	DEBİ 10 M.S.S FLOW 10 M.W.C	Trifaze Kod / Code	FİYATI (€) PRICE
40	80 lt Önfiltrli pompa Pump with prefilter (80 lt)	485 m <sup>3</sup> /saat m <sup>3</sup> /hour	PTF-400	9.480
50	80 lt Önfiltrli pompa Pump with prefilter (80 lt)	510 m <sup>3</sup> /saat m <sup>3</sup> /hour	PTF-500	10.174
60	80 lt Önfiltrli pompa Pump with prefilter (80 lt)	525 m <sup>3</sup> /saat m <sup>3</sup> /hour	PTF-600	10.925

### ÖN FİLTRESİZ TERMOPLASTİK SU POMPALARI THERMOPLASTIC WATER PUMPS WITHOUT PREFILTER

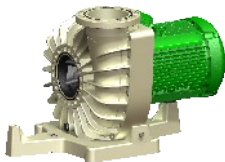

HP	MALZEME CİNSİ DESCRIPTION	DEBİ 10 M.S.S FLOW 10 M.W.C	Trifaze Kod / Code	FİYATI (€) PRICE
40	Önfiltrsiz pompa Pump without prefilter	500 m <sup>3</sup> /saat m <sup>3</sup> /hour	PT-400	8.629
50	Önfiltrsiz pompa Pump without prefilter	525 m <sup>3</sup> /saat m <sup>3</sup> /hour	PT-500	9.325
60	Önfiltrsiz pompa Pump without prefilter	540 m <sup>3</sup> /saat m <sup>3</sup> /hour	PT-600	10.074

⚡ **50 HZ - 1450 d/dak.  
rpm**

- ⚡ Elektrik bağlantısı; (3 Faz- Δ 400 / Y 690 V) 50 Hz 1450 devir/dakika  
Electrical Connection; (3 ph- Δ 400 / Y 690 V) 50 Hz 1450 rpm
- ⚡ Y / D - Bağlantı (3 Sn Y çalışacak sonra D'e geçecek)  
Y / D - Connection (3 Sec. work Y then go to D)
- ⚡ Diğer voltaj ve frekanslarda pompalar üretilmektedir.  
Special voltages and frequencies are manufactured on request.

## SÜPER SESSİZ 40 - 50 - 60 HP PERFORMANS EĞRİLERİ PERFECTLY SILENT 40 - 50 - 60 HP PERFORMANCE RANGE

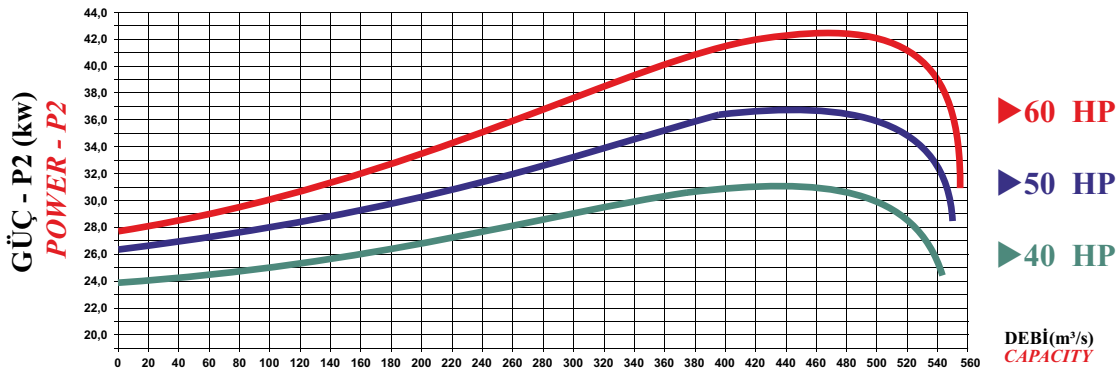
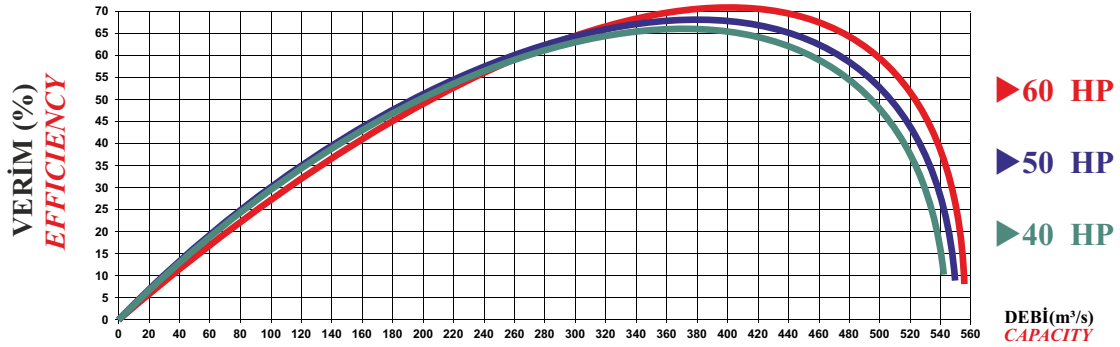
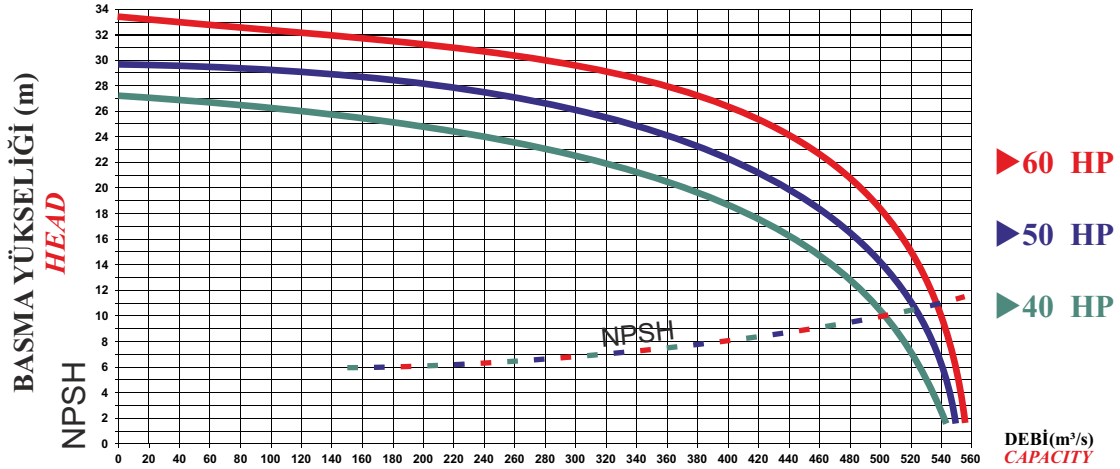

Ön filtresiz pompa eğrileri, TSE EN ISO 9906 standartlarına uygundur.  
Without prefilter pump curves comply with TSE EN ISO 9906 standards.

### GERÇEK TEST VERİLERİDİR REAL TEST VALUES

GÜÇ POWER	BASMA YÜKSELİĞİ - HEAD (m)					
	8	12	16	20	24	28
	DEBİ - CAPACITY (m³/h)					
40 HP	515	490	445	410	245	-
50 HP	535	515	485	465	365	210
60 HP	545	535	515	505	445	360

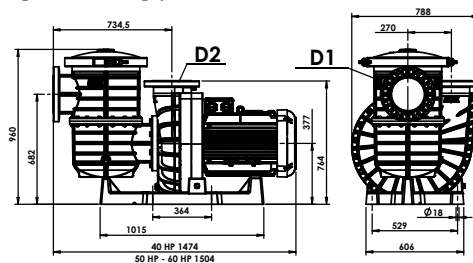

HP	METRIC ISO / DIN		IMPERIAL BS / ANSI / ASTM / AS / NZS	
	D1 / D2	mm	D1 / D2	mm
40		225	8"	219,4
50		225	8"	219,4
60		225	8"	219,4

Özgül Ağırlık : 1 gr/cm³ Sıcaklık : 20 °C Su için geçerli değerlerdir.  
Specific Gravity Temperature Current values for water.

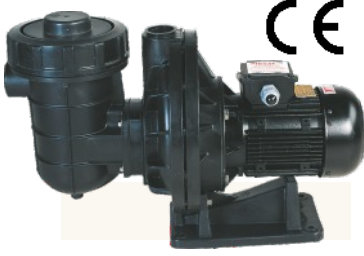

**ASİT POMPALARI**  
**ACID PUMPS****NOZBART KENDİNDEN EMİŞLİ ÖNFİLTRELİ TRİFAZE TERMOPLASTİK ASİT POMPALARI**  
**NOZBART SELF-PRIMING TRIPHASE THERMOPLASTIC ACID PUMPS WITH PREFILTER**

MALZEME CİNSİ DESCRIPTION	DEBİ 9 M.S.S. FLOW 9 M.W.C.	dBA Maks. Verimde at Max. Efficiency	KOD CODE	FİYATI(€) PRICE	AĞIRLIK WEIGHT
1 HP Önfiltreli asit pompası 1 HP Acid pump with prefilter	17 m <sup>3</sup> /saat m <sup>3</sup> /hour	64,5	PTFA-010	1.031	17.300 gr.
1,5 HP Önfiltreli asit pompası 1,5 HP Acid pump with prefilter	21 m <sup>3</sup> /saat m <sup>3</sup> /hour	65	PTFA-015	1.060	18.400 gr.
2 HP Önfiltreli asit pompası 2 HP Acid pump with prefilter	24,5 m <sup>3</sup> /saat m <sup>3</sup> /hour	64	PTFA-020	1.213	21.600 gr.

\* Kendinden emişli, CE Belgeli  
\* Self priming, CE Certificate

**NOZBART ÖNFİLTRESİZ TRİFAZE TERMOPLASTİK ASİT POMPALARI**  
**NOZBART TRIPHASE THERMOPLASTIC ACID PUMPS WITHOUT PREFILTER**

MALZEME CİNSİ DESCRIPTION	DEBİ 9 M.S.S. FLOW 9 M.W.C.	dBA Maks. Verimde at Max. Efficiency	KOD CODE	FİYATI(€) PRICE	AĞIRLIK WEIGHT
1 HP Önfiltresiz asit pompası 1 HP Acid pump without prefilter	17,5 m <sup>3</sup> /saat m <sup>3</sup> /hour	64,5	PTA-010	962	14.500 gr.
1,5 HP Önfiltresiz asit pompası 1,5 HP Acid pump without prefilter	21,6 m <sup>3</sup> /saat m <sup>3</sup> /hour	65	PTA-015	1.016	15.500 gr.
2 HP Önfiltresiz asit pompası 2 HP Acid pump without prefilter	25,2 m <sup>3</sup> /saat m <sup>3</sup> /hour	64	PTA-020	1.112	18.800 gr.

\* CE Belgeli  
\* CE Certificate

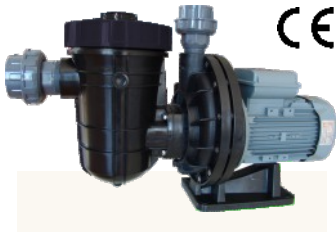
**NOZBART KENDİNDEN EMİŞLİ ÖNFİLTRELİ MONOFAZE TERMOPLASTİK ASİT POMPALARI**  
**NOZBART SELF-PRIMING MONOPHASE THERMOPLASTIC ACID PUMPS WITH PREFILTER**

MALZEME CİNSİ DESCRIPTION	DEBİ 9 M.S.S. FLOW 9 M.W.C.	dBA Maks. Verimde at Max. Efficiency	KOD CODE	FİYATI(€) PRICE	AĞIRLIK WEIGHT
1 HP Önfiltreli asit pompası 1 HP Acid pump with prefilter	17 m <sup>3</sup> /saat m <sup>3</sup> /hour	64,5	PMFA-010	1.031	17.700 gr.
1,5 HP Önfiltreli asit pompası 1,5 HP Acid pump with prefilter	21 m <sup>3</sup> /saat m <sup>3</sup> /hour	65	PMFA-015	1.060	22.100 gr.
2 HP Önfiltreli asit pompası 2 HP Acid pump with prefilter	24,5 m <sup>3</sup> /saat m <sup>3</sup> /hour	64	PMFA-020	1.213	23.800 gr.

\* Kendinden emişli, CE Belgeli  
\* Self priming, CE Certificate

**NOZBART ÖNFİLTRESİZ MONOFAZE TERMOPLASTİK ASİT POMPALARI**  
**NOZBART MONOPHASE THERMOPLASTIC ACID PUMPS WITHOUT PREFILTER**

MALZEME CİNSİ DESCRIPTION	DEBİ 9 M.S.S. FLOW 9 M.W.C.	dBA Maks. Verimde at Max. Efficiency	KOD CODE	FİYATI(€) PRICE	AĞIRLIK WEIGHT
1 HP Önfiltresiz asit pompası 1 HP Monophase acid pump	17,5 m <sup>3</sup> /saat m <sup>3</sup> /hour	64,5	PMA-010	962	14.800 gr.
1,5 HP Önfiltresiz asit pompası 1,5 HP Monophase acid pump	21,6 m <sup>3</sup> /saat m <sup>3</sup> /hour	65	PMA-015	1.016	20.200 gr.
2 HP Önfiltresiz asit pompası 2 HP Acid pump without prefilter	25,2 m <sup>3</sup> /saat m <sup>3</sup> /hour	64	PMA-020	1.112	22.900 gr.

\* CE Belgeli  
\* CE Certificate

50 HZ - 2850 d/dak  
rpm

Elektrik bağlantısı; (1 Faz - 220 V) - (3 Faz- D 220 / Y 380 V) 50 Hz 2850 devir/dakika  
Electrical Connection; (1 ph -220 V) - (3 ph- D 220 / Y 380 V) 50 Hz 2850 rpm  
Diğer voltaj ve frekanslarda pompalar üretilmektedir.  
Special voltages and frequencies are manufactured on request.

## 1-1,5-2-3 HP PERFORMANS EĞRİLERİ 1-1,5-2-3 HP PERFORMANCE RANGE

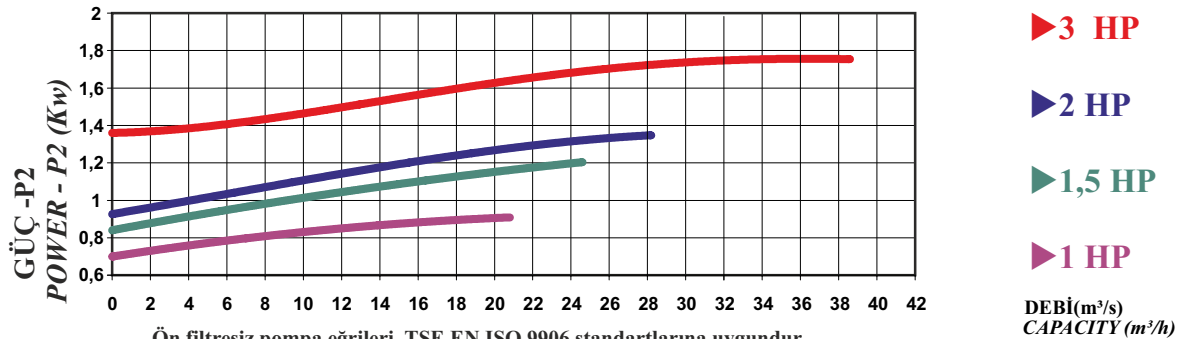
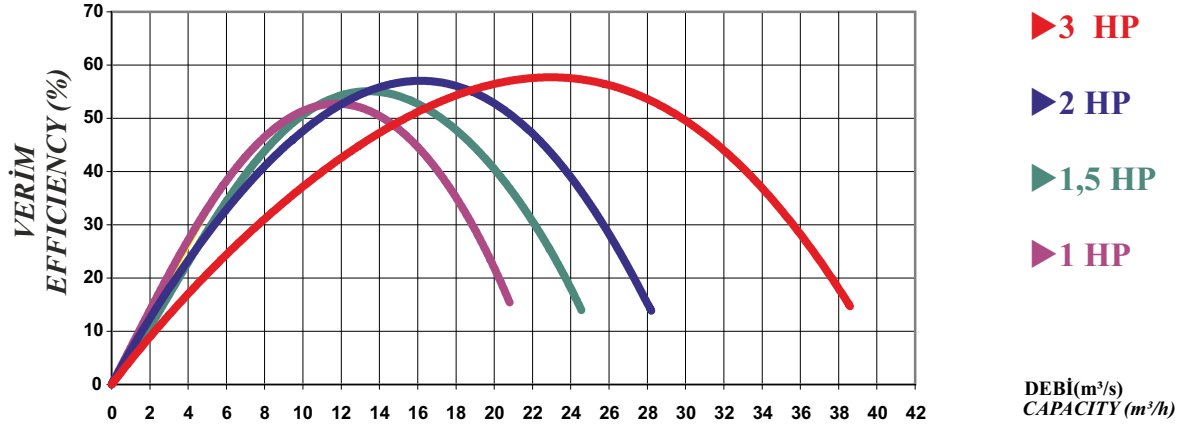
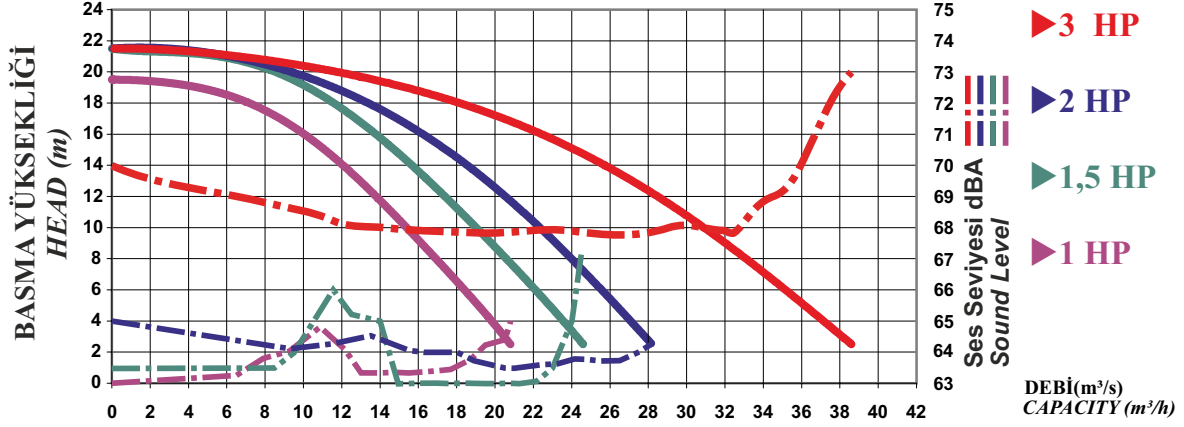

Ön filtresiz pompa eğrileri, TSE EN ISO 9906 standartlarına uygundur.  
Without prefilter pump curves comply with TSE EN ISO 9906 standards.

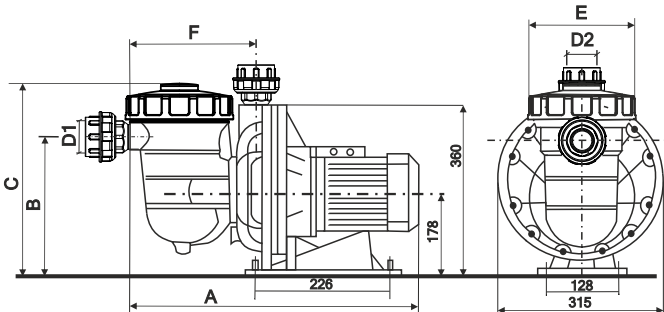

### GERÇEK TEST VERİLERİ REAL TEST VALUES

GÜÇ POWER	BASMA YÜK. - HEAD (m)							
	6	8	10	12	14	16	18	20
1 HP	19	17	15	14	12	10	7	
1,5 HP	22	21	19	17	16	14	11	8
2 HP	25	24	23	21	19	17	13	10
3 HP	35	33	31	29	26	23	18	12

Özgül Ağırlık  
Specific Gravity : 1 gr/cm<sup>3</sup>

Sıcaklık  
Temperature : 20 °C

Akışkan için geçerli değerlerdir.  
Current values for fluid

POMPA PUMP	A	B	C	F	E	D1	D2	D1	D2
	mm	mm	mm	mm	mm	mm	mm	Ansi	Ansi
1 HP - 1,5 HP	616	280	385	242	203	63	60	2"	1 1/2"
2 HP - 3 HP	650	292	415	276	230	75	63	2 1/2"	2"

**NOZBART POMPA ÖNFİLTRELERİ**  
**NOZBART PUMP PREFILTERS**

MALZEME CİNSİ DESCRIPTOR	GİRİŞ INLET	ÇIKIŞ OUTLET	KOD CODE	FİYATI PRICE (€)	HACİM VOLUME	MODEL MODEL
1 ½" Girişli pompa önfiltrresi 1 ½" Inlet pump prefilter	50	63	PKT-Ş50	<b>164,01</b>	3,9 lt.	ŞİRİN
2" Girişli pompa önfiltrresi 2" Inlet pump prefilter	63	63	PKT-Ş63	<b>164,01</b>	3,9 lt.	ŞİRİN
2" Girişli pompa önfiltrresi 2" Inlet pump prefilter	63	75	PKT-C63	<b>185,31</b>	7,5 lt.	COŞKUN
2 ½" Girişli pompa önfiltrresi 2 ½" Inlet pump prefilter	75	75	PKT-C75	<b>185,31</b>	7,5 lt.	COŞKUN
3" Girişli pompa önfiltrresi 3" Inlet pump prefilter	90	110	PKT-090	<b>441,62</b>	12,8 lt.	HUZUR
4" Girişli pompa önfiltrresi 4" Inlet pump prefilter	110	110	PKT-110	<b>441,62</b>	12,8 lt.	TUFAN TAŞKIN
4" Girişli pompa önfiltrresi 4" Inlet pump prefilter	110	110	PKT-111	<b>690,12</b>	20,0 lt.	SÜPER TUFAN
4 ½" Girişli pompa önfiltrresi 4 ½" Inlet pump prefilter	125	110	PKT-125	<b>690,12</b>	20,0 lt.	SÜPER TUFAN
8" Girişli pompa önfiltrresi 8" Inlet pump prefilter	225	225	PKT-225	<b>1.953,21</b>	80,0 lt.	TSUNAMI SULTAN



**ÖN FİLTRE DEBİ&KAYIP EĞRİSİ**  
**PREFILTER FLOW&LOSS CURVE**

— 2" Şirin — 2 ½" Coşkun — 4" Tufan-Taşkın-Huzur — 4 ½" Süper Tufan

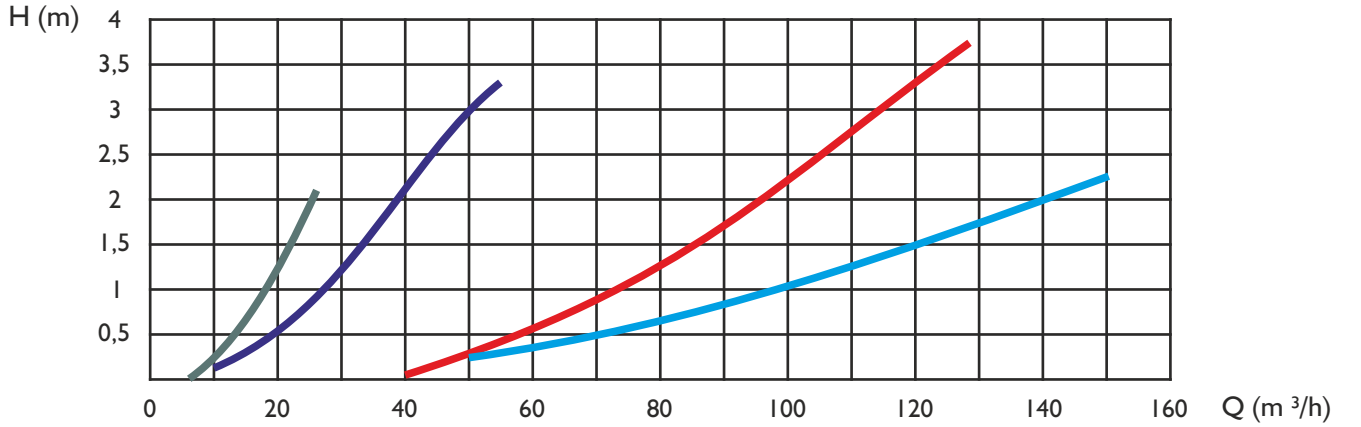

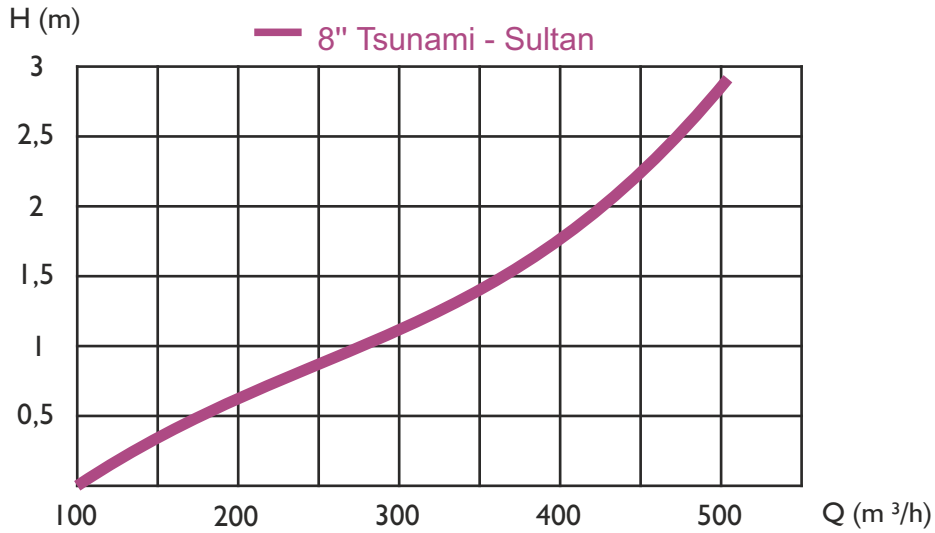
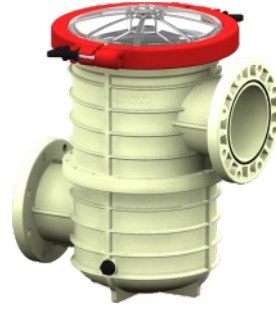

## PASLANMAZ ÇELİK ÖNFİLTRELER STAINLESS STEEL PREFILTERS

MALZEME CİNSİ DESCRIPTON	KOD CODE	FİYATI PRICE (€)	AMBALAJ PACKAGE
2 ½" Önfilte (Dişli bağlantılı) 304 Kalite 2 ½" Prefilter (Threaded connection) AISI 304	PÇÖ-075	***	1 ADET 1 UNIT
3" Önfilte (Dişli bağlantılı) 304 Kalite 3" Prefilter (Threaded connection) AISI 304	PÇÖ-090	***	1 ADET 1 UNIT
4" Önfilte (Dişli bağlantılı) 304 Kalite 4" Prefilter (Threaded connection) AISI 304	PÇÖ-110	***	1 ADET 1 UNIT
5" Önfilte (Dişli bağlantılı) 304 Kalite 5" Prefilter (Threaded connection) AISI 304	PÇÖ-140	***	1 ADET 1 UNIT
6" Önfilte (Dişli bağlantılı) 304 Kalite 6" Prefilter (Threaded connection) AISI 304	PÇÖ-160	***	1 ADET 1 UNIT



**KAUÇUK KOMPANSATÖR (ANTI-TİTREŞİM)**  
**RUBBER EXPANSION JOINT (ANTI-VIBRATION)**

MALZEME CİNSİ DESCRIPTON	KOD CODE	FİYATI PRICE (€)	AMBALAJ PACKAGE
DN 50 Kauçuk Kompansatör (Anti-titreşim) PN 16 DN 50 Rubber Expansion Joint (Anti-Vibration) PN 16	KOM-050	***	1 ADET 1 UNIT
DN 65 Kauçuk Kompansatör (Anti-titreşim) PN 16 DN 65 Rubber Expansion Joint (Anti-Vibration) PN 16	KOM-065	***	1 ADET 1 UNIT
DN 80 Kauçuk Kompansatör (Anti-titreşim) PN 16 DN 80 Rubber Expansion Joint (Anti-Vibration) PN 16	KOM-080	***	1 ADET 1 UNIT
DN 100 Kauçuk Kompansatör (Anti-titreşim) PN 16 DN 100 Rubber Expansion Joint (Anti-Vibration) PN 16	KOM-100	***	1 ADET 1 UNIT
DN 125 Kauçuk Kompansatör (Anti-titreşim) PN 16 DN 125 Rubber Expansion Joint (Anti-Vibration) PN 16	KOM-125	***	1 ADET 1 UNIT
DN 150 Kauçuk Kompansatör (Anti-titreşim) PN 16 DN 150 Rubber Expansion Joint (Anti-Vibration) PN 16	KOM-150	***	1 ADET 1 UNIT
DN 200 Kauçuk Kompansatör (Anti-titreşim) PN 16 DN 200 Rubber Expansion Joint (Anti-Vibration) PN 16	KOM-200	***	1 ADET 1 UNIT
DN 250 Kauçuk Kompansatör (Anti-titreşim) PN 16 DN 250 Rubber Expansion Joint (Anti-Vibration) PN 16	KOM-250	***	1 ADET 1 UNIT
DN 300 Kauçuk Kompansatör (Anti-titreşim) PN 16 DN 300 Rubber Expansion Joint (Anti-Vibration) PN 16	KOM-300	***	1 ADET 1 UNIT

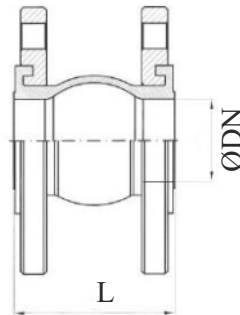

Anma Çapı / Nominal Diameter	DN	20	25	32	40	50	65	80	100	125	150	200	250	300	
Boy / Length	L	93				99	108	116	129	142	156	177	206	217	
<b>Hareket Yeteneği / Reaction Ability</b>															
Doğrusal / Linear	Max.	8		12			16			20					
	Min.	4		6			10			14					
Açısal / Angular	<°	15													



## CAM ELYAF TAKVİYELİ ETANJ PANOLAR FIBERGLASS REINFORCED POLYESTER BOARDS

MALZEME CİNSİ DESCRIPTION	Tek Motorlu Single Motored		Çift Motorlu Double Motored		Üç Motorlu Three Motored	
	KOD CODE	FİYATI PRICE (€)	KOD CODE	FİYATI PRICE (€)	KOD CODE	FİYATI PRICE (€)
1/4-3 HP Pompalar için özel panolar Special board for 1/4-3HP pumps	PAN-0130	600,66	PAN-0230	1.202,74	PAN-0330	1.803,40
3,5-5,5 HP Pompalar için özel panolar Special board for 3,5-5,5 pumps	PAN-0155	630,48	PAN-0255	1.259,54	PAN-0355	1.890,02

- \* Siemens termik röle ve kontaktörlü
- \* Pako şalterli, faz ve kaçak akım koruma röleli
- \* Harici priz ve w otomat korumalı
- \* Dozaj pompası ve lambalı bağlantılı
- \* Lütfen fiyat sorunuz

- \* Siemens thermic relay and conductor
- \* Paco switch, phase and leakage current relay
- \* External plug and protective w automation
- \* Dosing pump and light connection
- \* Please consult us

## YUMUŞAK KALKIŞLI CAM ELYAF TAKVİYELİ ETANJ PANOLAR FIBERGLASS REINFORCED POLYESTER BOARDS WITH SOFTSTARTER

MALZEME CİNSİ DESCRIPTION	Tek Motorlu Single Motored		Çift Motorlu Double Motored		Üç Motorlu Three Motored	
	KOD CODE	FİYATI PRICE (€)	KOD CODE	FİYATI PRICE (€)	KOD CODE	FİYATI PRICE (€)
7,5 HP Pompalar için özel panolar Special board for 7,5-12,5 HP pumps	PAN-0176	1.126,06	PAN-0276	2.252,12	PAN-0376	3.376,76
10 HP Pompalar için özel panolar Special board for 10 HP pumps	PAN-0111	1.265,72	PAN-0211	2.530,44	PAN-0311	3.795,66
12,5-15 HP Pompalar için özel panolar Special board for 12,5-15 HP pumps	PAN-0116	1.425,68	PAN-0216	2.851,36	PAN-0316	4.275,62
20 HP Pompalar için özel panolar Special board for 20 HP pumps	PAN-0121	1.675,60	PAN-0221	3.349,78	PAN-0321	5.025,38
25 HP Pompalar için özel panolar Special board for 25 HP pumps	PAN-0126	1.897,12	PAN-0226	3.794,24	PAN-0326	5.689,94
30 HP Pompalar için özel panolar Special board for 30 HP pumps	PAN-0132	2.428,20	PAN-0232	4.857,82	PAN-0332	7.286,02
40 HP Pompalar için özel panolar Special board for 40 HP pumps	PAN-0141	*	PAN-0241	*	PAN-0341	*
50 HP Pompalar için özel panolar Special board for 50 HP pumps	PAN-0151	*	PAN-0251	*	PAN-0351	*
60 HP Pompalar için özel panolar Special board for 60 HP pumps	PAN-0161	*	PAN-0261	*	PAN-0361	*

- \* Pako şalterli, faz ve kaçak akım koruma röleli
- \* Harici priz ve w otomat korumalı
- \* Dozaj pompası ve lambalı bağlantılı
- \* Lütfen fiyat sorunuz

- \* Paco switch, phase and leakage current relay
- \* External plug and protective w automation
- \* Dosing pump and light connection
- \* Please ask for price

**SIVI SEVİYE KONTROL RÖLELERİ**  
**LIQUID LEVEL CONTROLLER**

MALZEME CİNSİ DESCRIPTON	KOD CODE	FİYATI PRICE (€)
Sıvı seviye kontrol rölesi Liquid level controller	SSK-001	*

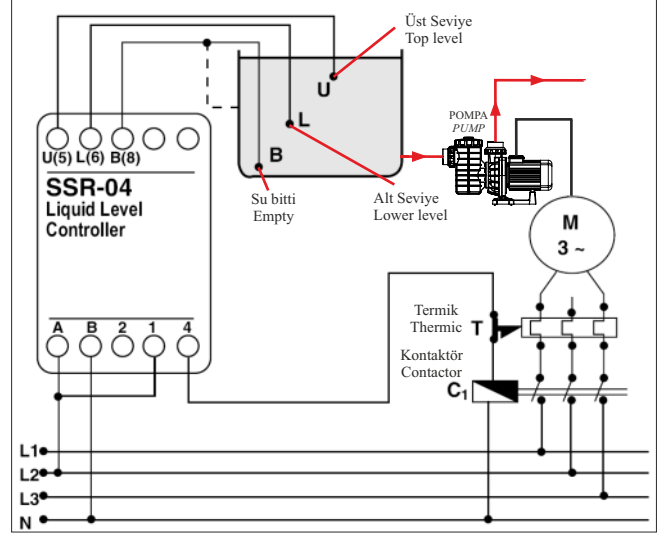
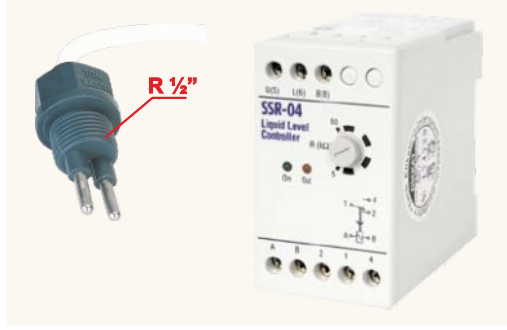

**PLASTİK POMPA SEHPASI**  
**PLASTIC PUMP STAND**

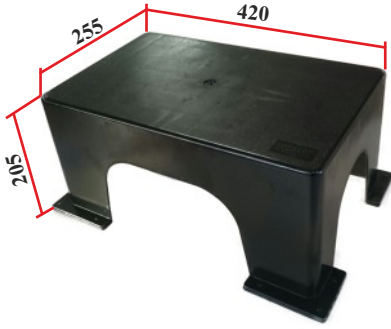

**TEK POMPA İÇİN /// FOR ONE PUMP**

MALZEME CİNSİ DESCRIPTON	KOD CODE	a x b x h	FİYATI PRICE (€)
Plastik tekli pompa sehpası (Hamsi-Şirin-Coşkun-İlk Seri) Plastic pump stand-single (Hamsi-Şirin-Coşkun-İlk Series)	PSP-001	420x255x205	19,88

**PASLANMAZ ÇELİK POMPA SEHPALARI**  
**STAINLESS STEEL PUMP STAND**

**TEK POMPA İÇİN /// FOR ONE PUMP**

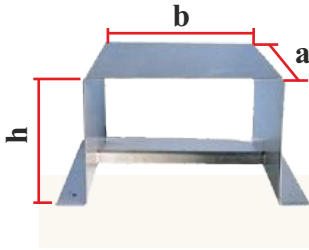

MALZEME CİNSİ DESCRIPTON	KOD CODE	a x b x h	FİYATI PRICE (€)
Şirin serisi paslanmaz çelik tekli pompa sehpası Şirin series stainless steel pump stand-single	ÇPS-100	355x190x200	*
Coşkun serisi paslanmaz çelik tekli pompa sehpası Coşkun series stainless steel pump stand-single	ÇPS-200	425x275x200	*
Huzur serisi paslanmaz çelik tekli pompa sehpası Huzur series stainless steel pump stand-single	ÇPS-300	506x365x200	*
Taşkın ve Tufan serisi paslanmaz çelik tekli pompa sehpası Taşkın and Tufan series stainless steel pump stand-single	ÇPS-400	585x315x200	*

**ÇİFT POMPA İÇİN /// FOR TWO PUMPS**

MALZEME CİNSİ DESCRIPTON	KOD CODE	a x b x h	FİYATI PRICE (€)
Şirin serisi paslanmaz çelik çiftli pompa sehpası Şirin series stainless steel pump stand-double	ÇPS-101	355x580x200	*
Coşkun serisi paslanmaz çelik çiftli pompa sehpası Coşkun series stainless steel pump stand-double	ÇPS-201	425x750x200	*
Huzur serisi paslanmaz çelik çiftli pompa sehpası Huzur series stainless steel pump stand-double	ÇPS-301	506x930x200	*
Taşkın ve Tufan serisi paslanmaz çelik çiftli pompa sehpası Taşkın and Tufan series stainless steel pump stand-double	ÇPS-401	585x830x200	*

\* Lütfen fiyat sorunuz  
Please consult us

## POMPA UYGULAMALARI PUMP APPLICATIONS

### Paralel Bağlı Pompalar//Pumps Connected in Parallel

Pompalar paralel bağlanarak debi arttırılabilir. Paralel bağlanan çok sayıda pompanın oluşturduğu sistemin performans eğrisi belli bir basma yüksekliğindeki debilerinin toplamı ile elde edilir. Örnek olarak iki eş pompanın paralel bağlandığı bir sistemde basma yüksekliğinin her değeri için debi tekli çalışmaya göre iki katına çıkacaktır. Bypass dolaşımı ile kaçacağı engellemek için pompa çıkışlarına birer çekvalf konmalıdır.

Flow can be increased by connecting pumps in parallel. Performance curve of the system, that is composed by several pumps connected in parallel, is obtained by sum of the flows of the head. As an example, in a system of two identical pumps connected in parallel, flow will be doubled for each value of head, compared to single run. In order to prevent feedback on the other pump, it is necessary to put check valve on the output of each pump.

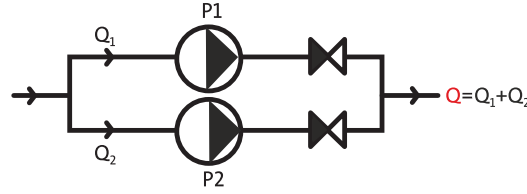
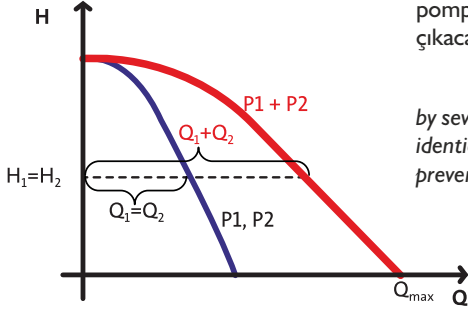

### Seri Bağlı Pompalar//Pumps Connected in Series

Pompalar seri bağlanarak basınç arttırılabilir. Seri bağlanan çok sayıda pompanın oluşturduğu sistemin performans eğrisi belli bir debi değerindeki basma yüksekliklerinin toplamı ile elde edilir. Örnek olarak iki eş pompanın seri bağlandığı bir sistemde debinin her değeri için basma yüksekliği tekli çalışmaya göre iki katına çıkacaktır. Her pompa birer çekvalf ile by pass yapılarak pompaların tekli çalışmaları halinde direnç azaltılmış olur.

Pressure can be increased by connecting pumps in series. Performance curve of the system that is composed by several pumps connected in series, is obtained by sum of heads of the flow. As an example, in a system of two identical pumps connected in series, head will be doubled for each value of flow, compared to single run. Each pump is by-passed by one check valve. Resistance is reduced by single work of the pump.

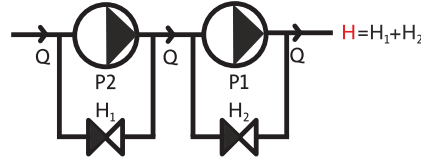
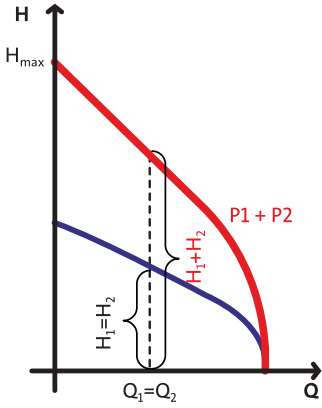

### Hız (Frekans) Kontrollü Pompalar//Speed (Frequency) Controlled Pumps

Motor devir sayısını değiştirerek debiyi ve basıncı arttırıp, azaltabiliriz. Bu değerler yandaki formüllere göre değişir. Buradan anlaşılacağı gibi pompanın normal devrinden daha düşük değerde çalıştırılacaksa sorun olmaz, güvenle çalıştırabilirsiniz. Normal devrinden daha yüksek devirlere çalıştırılacaksa güç devir sayısı oranının küpü ile orantılı artacaktır. Pompa seçiminde ARGÉ bölümüne danışabilirsiniz. Size hizmet etmekten onur duyacağız.

It is possible to increase or decrease flow and pressure by changing the number of motor cycle. These values vary according to the formulas on the left side. As can be seen here, it is safe to operate pump in a value lower than its normal value, power will increase in the same ratio of the cube of number of cycles. For selection of the pump, you can consult our research and development department. We will be honored to support you.

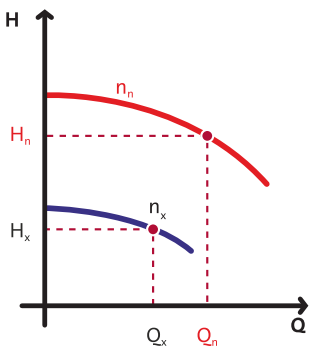

### Hız Kontrolü//Speed Control

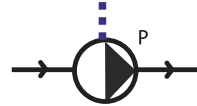

Debi

Basınç

Güç

$$\frac{Q_x}{Q_N} = \frac{n_x}{n_N}$$

$$\frac{H_x}{H} = \left(\frac{n_x}{n_N}\right)^2$$

$$\frac{P_x}{P_N} = \left(\frac{n_x}{n_N}\right)^3$$

Q= Debi (Flow) m<sup>3</sup>/saat  
H= Basma Yüksekliği (Head) m  
n= Devir (rpm)  
P= Güç (Power) kw  
x= İstlenen Değer (Setpoint)  
N=Nominal Değer (Nominal Value)

7,5 - 10 - 12,5 - 15 - 20 - 25 - 30  
40 - 50 - 60 HP

**Y-D GÜÇ ŞEMASI**

**Y-D ELECTRICAL CONNECTION**

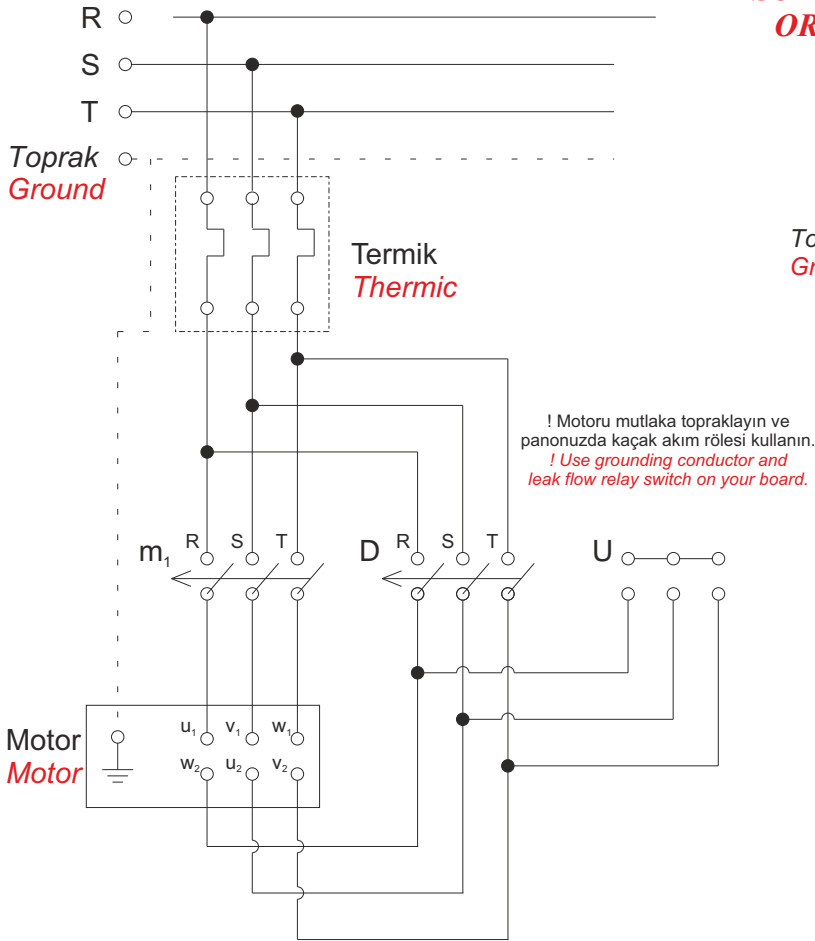

**İLK ÇALIŞTIRMA**

Önce Y ve m<sub>1</sub> kontaktörü 3 saniye devreye girecek. Sonra zaman rölesi Y kontaktörünü devreden çıkaracak  
D kontaktörünü devreye alarak zaten devrede olan m<sub>1</sub> kontaktörü ile birlikte devamlı çalışacaktır.

**WARNING DURING START UP**

Star Delta Motor Starting: See connection and wiring diagrams. When the operating voltage is applied, the star (Y) and m<sub>1</sub> contacts are closed and then released after the operating time, 3 sec. The delta (D) contacts and m<sub>1</sub> are closed after the transition time (fixed at factory).

HER GÜÇTEKİ POMPA İÇİN  
YUMUŞAK YOL VERİCİ VEYA  
DEĞİŞKEN FREKANSLI SÜRÜCÜ  
GÜÇ ŞEMASI

**SOFT STARTER ELECTRICAL CONNECTION  
OR VARIABLE FREQUENCY DRIVE (VFD)**

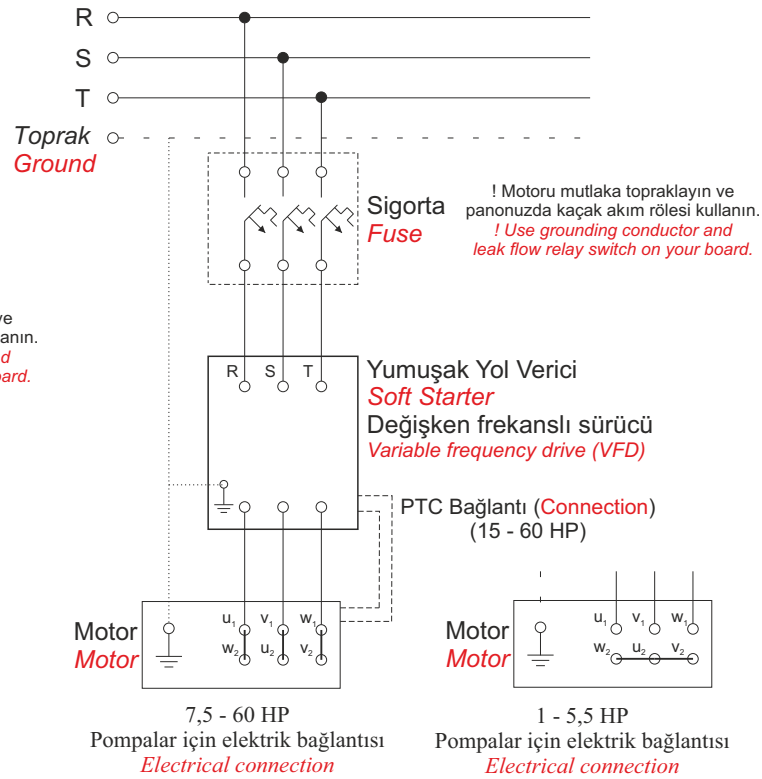

Yumuşak yol verici tam motor gücünde seçilmelidir, küçük yada büyük olmamalıdır. Tavsiye edilen Yumuşak yol verici hem kalkış hem duruş ayarlı olmalıdır.

Select a soft starter according to the rated motor power, must not be more or less. Soft starter recommended should be with adjustment of start and stop.

Gücü kapatın ve pompaya bakım yapmadan önce beş dakika bekleyiniz. Turn off power and wait 5 minutes before servicing pump.

**1/2 - 5,5 HP Trifaze Güç Şeması**  
*1/2 - 5,5 HP Triphase Electrical Connection*

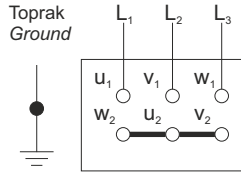

**1/4 - 3 HP Monofaze Güç Şeması**  
*1/4 - 3 HP Monophase Electrical Connection*

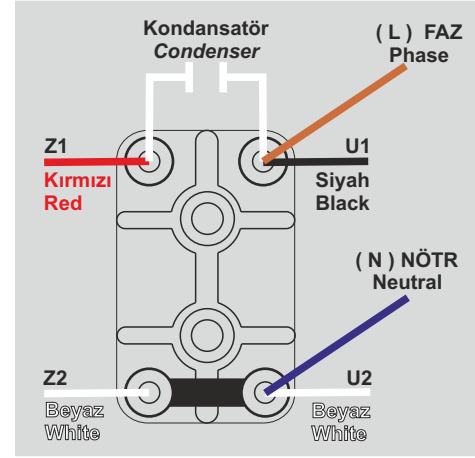

**MONOFAZE POMPA PANOLARINDA  
DİKKAT EDİLMESİ GEREKLİ HUSUSLAR**

GÜÇ		SİGORTA	TERMİK
HP	KW	A	A
1/4	0,18	4-6	1,7
1/3	0,25	4-6	2,1
1/2	0,37	4-6	3,1
3/4	0,55	4-6	4,4
1	0,75	6	5,5
1,5	1,1	6	5,5
2	1,5	16	5,6
3	2,2	20	8,3

Termik Bağlantısı (Aşağıdaki şekilde yapılmalıdır.)

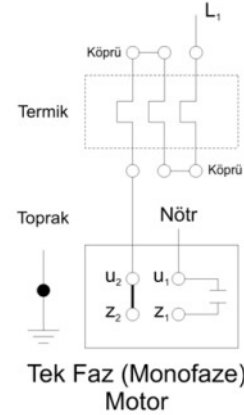

**TS EN ISO 9906 Pompa Performans Kabul Deneyleri Standardı / *Pump Performance Acceptance Tests***

Müsaade edilebilir toplam belirsizlik değerleri / *Permissible values of overall measurement uncertainties*

Büyüklik ( <i>Quantity</i> )	Sembol / <i>Symbol</i>	Tüm Plastik %	Sınıf 1 / <i>Grade 1</i> %	Sınıf 2 / <i>Grade 2</i> %
Debi ( <i>Flow Rate</i> )	$e_Q$	± 2,0	± 2,0	± 3,5
Pompa toplam (basma) yükü <i>Pump total head</i>	$e_H$	± 1,0	± 1,5	± 5,5
Pompa giriş gücü (tahrik gücü ve motor veriminden hesaplanan) <i>Pump power input (computed from driver power and motor effc.</i>	$e_p$	± 1,0	± 2,0	± 4,0

## YÜZME HAVUZU POMPALARININ YERLEŞTİRİLMESİ VE KULLANILMASINDA DİKKAT DİLECEK HUSUSLAR

Dışarıdan suya enerji vererek, giriş enerjisinden daha büyük bir enerji ile çıkmasını sağlayan makinalara POMPA denir. Havuzlarda istenen su niteliklerini aynı seviyede tutmak için devamlı sirkülasyona, dolayısıyla bu işlevi yapacak pompaya ihtiyaç vardır. Pompa; suyun havuzdan filtreye, ısıtıcıya, besleyicilere ve tekrar havuza devamlı akışını temin eder. Havuzlarda genelde santrifüj pompalar kullanılır.

Boru tesisatı ve yukarıda belirtilen sistem elemanları tüm parçalar devridaim akışına karşı direnç oluşturur. Bu direnç basma yüksekliği gibi metre su sütunu (mss) olarak ifade edilir. Bu dirence karşılık pompa, bir akış temin eder. Tesisattan saatte metre küp olarak geçen su miktarına debi denir ve m<sup>3</sup>/saat olarak ifade edilir. Pompa, sistemin bu direncini yenecek gerekli debiyi temin edecek şekilde seçilmelidir. Debi seçimi için UHE talimatı No: 1'e bakılabilir.

Her pompanın basma yüksekliğine bağlı debi diyagramı vardır. Pompa tipi bu diyagramdan seçilir.

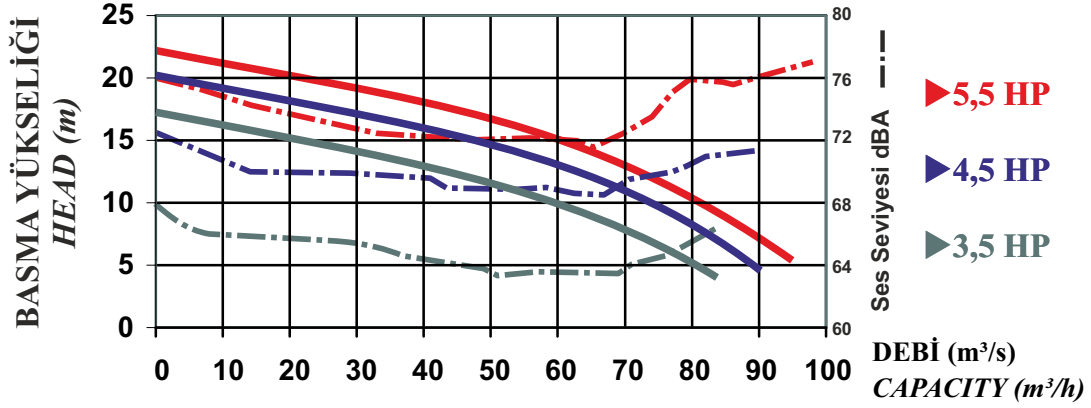

Bu diyagramdan anlaşılacağı gibi sistem direnci ne kadar düşükse, pompanın ürettiği akış o kadar büyük olur. Tersine direnç ne kadar büyükse akış o kadar küçük olur. Bu sebeple santrifüj pompa, temiz filtre ile çalıştığında filtrenin pis olduğu zamana oranla daha fazla akış üretir. Çıkış vanası kapatıldığında en büyük direnç gösterilmiş, akış kesilmiş olur. Pompa çarkı sadece suyu çalkalar, pompanın istediği enerji en küçük miktardadır. Bu sebeple büyük bir santrifüj pompanın ilk çalıştırılmasında elektrik devresinin zorlanmaması istenirse pompanın çıkış vanası kapatılmalı, pompa tam devrini aldıktan sonra açılmalıdır.

Bütün pompa üreticileri pompanın çalıştırılmasında basma tarafı vanasının kapalı pozisyonda olmasını tavsiye ederler ve böyle olmalıdır. Bu pozisyonda elektrik motoru en az enerjiyi çeker. Vana kapalı iken, pompa içindeki basıncın en yüksek değerde olması sizi yanıltmasın. Pompa su basmadığı için güç çekilmemektedir. Motor, suyu çalkalama, kendi sürtünmesi ve iç kaçakları dışında bir iş yapmamaktadır. Pompa tam devrini aldıktan sonra vana yavaş yavaş açılarak devreye su verilmelidir.

Altını çizerek şunu bir defa daha söyleyelim, pompanın emme tarafı vanası hiçbir şekilde kapatılmamalıdır. Bu vana sadece arıza halinde pompayı sökmek içindir. Eğer bir debi ayarı yapılacaksa sadece basma tarafı vanasından ayar yapılabilir. Pompa çalıştıktan sonra basma tarafı vanasını açmayı unutursak su devamlı çalkalama ve sürtünme neticesinde aşırı ısınacak, pompayı tahrip edecektir. Unutma tehlikesi söz konusu ise küçük çaplı bir boru ve vana ile basma vanasının iki tarafı baypas yapılabilir.

Pompaları emiş yapılacak su kaynağının olabildiğince yakınına yerleştirin, mümkünse direkt bağlayın. Son fittings ile pompa girişi arasına en az boru çapının beş katı uzunlukta düz boru yerleştirin. Pompa emiş hatlarından sisteme hava emdirilmemelidir. Titreşimi ve gürültüyü önlemek için pompanın emiş ve çıkış tarafına komparsatörler koyun. Pompayı zeminden yüksek sehpa üzerine titreşim söndürücü lastiklerle monte edin. Giriş ve çıkış borularının ağırlığı pompaya yüklenmemeli, pompaya ağırlık taşıtılmamalıdır. Boruların ekseni kelepçelerle pompanın giriş ve çıkış eksenine getirilmeli, rakorlar boruları çektirip eksene getirme aracı olarak kullanılmamalıdır. Pompa rakorları söküldüğünde boru ve pompa eksenlerinden sapmalar olmamalıdır.

Zorunlu olmadıkça pompaya emiş yaptırmayın. Üç metreden fazla emiş yüksekliği tavsiye edilmez. Pompa emiş su seviyesi pompa seviyesinden aşağıda ise emiş hattı en alçak noktadan, pompa girişi itibarı ile sürekli yukarı doğru meyilli olmalıdır. Pompa emiş su seviyesi pompa seviyesinden yukarıda ise pompa emişi yönünde devamlı aşağı doğru tesisat döşenmelidir. Herhangi bir noktadaki ters meyil hava cepleri oluşturur.

Emilen su seviyesinin pompa emişinden aşağıda olması, emiş hattının uzunluğu, boru çapının küçük seçilmesi, ön filtre süzgecinin küçük ve kirli olması emme hattındaki diğer elemanlar pompa çarkının emiş kesitindeki net pozitif yükün düşmesine ( NPSH – Net Pozitive Suction Head ) bu da kavitasyona sebep olur. Kavitasyon pompa çarkını kısa sürede tahrip eder. Pompa emiş hatlarında kesinlikle küçük çaplı boru seçilmemelidir. Pompanın giriş ve çıkış çapları boru seçiminde bir ölçü değeridir. UHE talimatı No: 1 'de pompa emiş hatları için maksimum hız 1.5 m/sn., basma hatları için maksimum hız 2.5 m/sn. olarak verilmektedir. 169. sayfada yüzme havuzu için boru seçimi tablosundan pompanın debisine bağlı olarak emme ve basma hatlarının boru çaplarını seçebilirsiniz.

Pompayı kuru ve taze hava sirkülasyonunun olduğu yere yerleştirin. Kapalı alana yerleştirilen pompanın motor soğutma fanı taze hava alamazsa kendi üzerinden geçen sıcak havayı tekrar motora verir. Motor soğuyamaz. Yüksek sıcaklıklarda çalışma, yalıtımda daha hızlı bozulma oluşturur. Bu da motorun ömrünün kısalması ile sonuçlanır. Elektrik kablosunun kesiti motor gücüne uygun seçilmelidir. Düşük voltaj, ihtiyaç olan gerekli gücün temini için ekstra amperin çekilmesine, bu da motorun aşırı ısınmasına sebep olur. Elektrik motoru termik röle, kaçak akım rölesi ile korunmalı ve sistem komple topraklanmalıdır.

Pompa motoru çalıştırılmadan önce soğutma fanı tarafından mil elle döndürülerek pompada herhangi bir cisim olup olmadığı anlaşılmalıdır. Pompalar kesinlikle susuz çalıştırılmaz. Mekanik seramik salmastralı pompalarda grafit parça seramik yüzeye yay kuvveti ile devamlı bastırılır ve dönme sırasında bu şekilde sürtünme sızdırmazlığı temin eder. Elektrik bağlantısından önce tesisatta su olsun veya olmasın ön filtreyi su ile doldurun. Pompada su varsa salmastra yüzeyleri arasında ince bir su filmi oluşur. Dönen parçalar bu su filmi üzerinde kayar. Genelde elektrik bağlantısı sırasında motorun dönüş yönünü görmek için pompalara su koymadan tecrübe çalıştırmaları yapılmaktadır. Böyle bir çalıştırmada dakikada 3000 defa dönen pompanın, salmastrası kuru sürtünme nedeniyle aşırı ısınır. Salmastranın contaları ve plastik yuvası tahrip olur. Daha yeni havuzu devreye almadan, pompa bozulmuş olur. Havuzun süpürülmesinde pompanın emişinden istifade edildiği sistemlerde de bu hal görülmektedir. Havuzun süpürgesi ve hortumu havuza sokulmadan pompa çalıştırılmakta, hava emen pompada yukarıdaki duruma sebebiyet verilmektedir. Emme tarafındaki vanası kapalı olarak çalıştırılan pompalarda da aynı arıza söz konusudur. Böyle bir arıza halinde pompanın motoru ile plastik kapağın hemen altından su damlamaya başlayacaktır.

Ön filtrenin şeffaf kapağından bakıldığında çalışmakta olan pompada hava kabarcıkları ve hava boşluğu görülmemelidir. On filtre sepetinin kirliliği pompayı oldukça zorlar, debinin düşmesine ve kavitasyona sebep olur. Sık sık temizlenmelidir. Donma tehlikesi olan yerlerde tahliye tapası açılarak pompadaki su boşaltılmalıdır. Hiçbir bakım istemeyen mekanik salmastralı pompalar yukarıdaki hususlara dikkat edilerek çalıştırıldığında size senelerce hizmet verebilir.

Pompa emiş hattının başına konan emiş süzgeçlerine çok önemli olduğu için değinmek istiyorum. TS EN 13451-3 standartının 4.6.1 nolu maddesinde belirtildiği gibi emiş yüzeyi hızı 0.5 m/sn den küçük olmalıdır. Bu yüzey pompa emiş hatlarında kullanılan boru çapları çizelgesinde verdiğimiz boru kesiti yüzeyinin 3 katı büyüklüğünde yüzeye denk gelir. İş bununlada bitmiyor standart, her pompa için 2m ötede aynı ölçülerde 1 adet daha emiş süzgeçi yapıp paralel bağlamamız şartını emrediyor.

En küçük pompa kullanmanızda dahi süzgeç emiş yüzeyi 1m<sup>2</sup> den büyük olmalıdır. Bir kullanıcı herhangi bir şekilde emiş yüzeyine geldiğinde yüzeyin %50 sinden daha fazlasını kapatmamalıdır. Yüzme havuzları kullanımda iken dip süzgeçlerinden emiş yaptırmayın. En küçük pompamız bile emiş hattı kapatıldığında 0,8 bar vakum oluşturur. 40x40 cm emiş süzgecine yapışacak kişiye 1280kg lık kuvvetle çekme uygulanmış olur.

Ucuzluk, boşveri, menfaat temini, banane gibi bahanelerle yapacağınız standart dışı süzgeçlere sevdiğinizin veya kendi çocuklarınızın da kapılıp ölebileceklerini lütfen unutmayalım.

**İBRAHİM HAKKI UYSAL**  
Genel Müdür  
Makina Yüksek Mühendisi



## THE ISSUES TO BE TAKEN INTO CONSIDERATION WHILE INSTALLING AND USING THE SWIMMING POOL PUMPS

The machines which ensures the water to go out with an energy that is bigger than the input energy by energizing it externally are called as PUMPS. A Pump is needed to keep the desired water attributes on desired levels and for a continuous circulation. The pump assures the continuous flow of water from the pool passing through filter, heater, feeders and to the pool again. Centrifugal pumps are commonly used in swimming pools.

Pipe system and system components mentioned above constitute a resistance against the flow circulation. This resistance is expressed with water column meter (wcm). The pump generates a flow as response to this resistance. The water amount which passes through the system in terms of cubic meter in an hour is called as flow rate and it's expressed with m<sup>3</sup>/hour. A pump has to be chosen to assure the required flow rate that will overcome the system resistance. UHE instructions No:1 should be checked for flow rate choice.

Each pump has a delivery head depended flow rate diagram. Pump type is chosen according to this diagram.

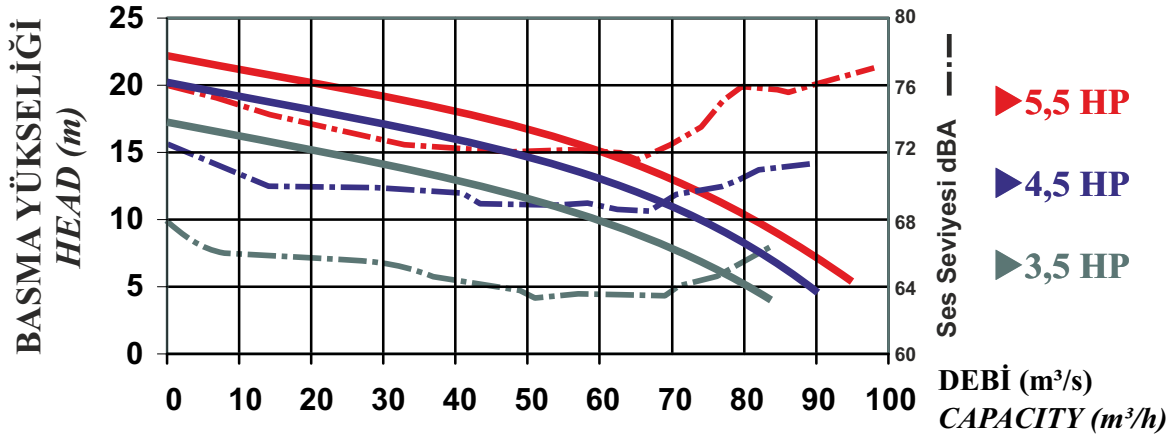

As seen in the diagram, when the system resistance is lower the flow is bigger. In contrast, the higher the resistance is the smaller the flow to be. Therefore the centrifugal pump generates much more flow when it is operated with a clean filter than the case that the filter is dirty. When the outlet valve is closed it means that the maximum resistance is occurred and the flow is cut. In this situation, the pump only shakes the water and the energy which is needed by the pump is at minimum. For this reason, when operating a big centrifugal pump for the first time, the pump outlet valve should be closed and the pump should be switched on whenever it reaches to the proper rpm level to avoid the electrical circuit overload.

Whole pump manufacturers recommend to bring the control valve on discharge side to turn-off position before running the pump and so it should be. In this position the electric motor consumes minimum energy. The pressure in the pump is at maximum level when the valves are turned-off. But do not let it to mislead you. Because the pump does not consume energy as it's not discharging. The motor does nothing more than shaking the water, self friction and internal leakage. When the pump reaches to full speed the valve should be turned on gradually to release the water to the system.

We would like to emphasize it one more time; the suction side control valve of the pump should never be turned off. This valve is only used for uninstillation of the pump in case of a malfunction. If a flow rate adjustment is needed, it can be done only through the discharge side control valve. If you forget to turn on the discharge side valve after running the pump, the water will overheat as a result of continuous swash and friction and this will damage the pump. If there is a danger of forgetting, both sides of the discharging valve can be by-passed with a small diameter pipe and a valve.

Install the pump as close as possible to the water source which the suction is going to be initialized and if possible connect it directly. Put a straight pipe which is five times longer than its diameter between the last fitting and the pump inlet. You shouldnt let the air enter to the system from pump suction lines.. Fix the pump to the ground to prevent the vibration and noise. The weight of inlet and outlet pipes should not be load on the pump, and the pump should not be forced to carry any kind of weight. The axis of pipes should be brought in the same axis of pump inlet and outlet with the help of clamps. Unions should not be used as a pulling and axis equalization instrument. When the pump unions, disconnected there shouldnt be deviations from pump and pump axes.

Do not have the pump do suction unless it is necessary. Suction height which is more than three meters is not recommended. If the pump water suction level is below the pump level; starting from pump inlet, the suction line should be continuously upward sloping from the lowest level. If the pump water suction level is above the pump level, the line should be installed continuously downward sloping and in the same direction with pump suction. A reverse slope at any direction generates air pockets.

Sucked water level falling below the pump suction, the length of suction line, choosing small diameter pipe, small and dirty prefilter basket and other components on suction line cause net positive head (NPSH – Net Positive Suction Head ) on suction section of pump impeller to decrease and this causes cavitation. Cavitation demolishes pump impeller in a short time. Pipes with small diameters should never be chosen for suction lines. Inlet and outlet pump diameter is not a measure on pipe selection. In UHE instructions No:1, the maximum speed for suction lines is given as 1.5 m/sec. and it's given as 2.5 m/sec. for discharge lines. Pipe diameter of suction and discharge lines according to flow of pump can be chosen from table of pipe choice for swimming pool on page 169.

Install the pump to a place which is dry and has a clean air circulation. If the ventilation fan of a pump which is installed in a closed area is not feeded with fresh air it will transmit the hot air that is passing over it back to the motor once more. So, the motor can not cool down. High temperature operation speeds up the deterioration in isolation. This ends up with a shortening in pump lifetime. The cross-section of the power cable should be chosen according to the power of the pump. The low voltage will cause an increase in the ampere consumed to assure the required power and this will trigger the pump to be overheated. The motor should be conserved with a thermic - leakage current relay and system completely should be grounded.

Before operating the pump, the shaft should be turned round by ventilation fan's side to check whether there is an object inside the pump. The pumps should never be run without water. In pumps with mechanical ceramic seals, the graphite component is pushed down to the ceramic surface continuously with a spring force and this friction assures leakproofing during rotation. Whether or not there is water in plumbing, before electricity connection, fill the prefilter with water. Usually, operators make a test run without filling the pump with water during the electrical connection process to see the direction of rotation. In this way of running, the mechanical seal which rotates 3000 times per minute, gets overheated. The gaskets and slot of the seal are damaged. Before putting a new pool in use the pump would be damaged. This is commonly seen in systems which the pump suction is utilized to brush the pool. In this case the pump is running before putting the pool brush and floating pipe into the pool and this cause the air to run into the pump and eventually the situation described above occurs. This malfunction is also same in the pumps which is run while the control valve on the suction side is turned-off. In case of such a failures, the water will start to drip right under the motor and the plastic cover of the pump.

When looked at the transparent cover of a running pump, bubbles and airholes should not be seen. The dirtiness of the prefilter overstrains the pump considerably. It causes cavitation and decrease in flow rate. It should be cleaned frequently. In places with a frost risk, The discharge cap should be opened and the water in the pump should be drained off. Pumps with mechanical seals which do not require any special maintenance will serve you for long years as long as they are run by considering the points explained above.

Because its very important, I would like to mention to the suction drains which is set on the beginning of the pump suction line. As it is indicated in TS EN 13451-3 standard, Article 4.6.1, suction surface speed must be smaller than 0,5 m/s. This is equivalent to 3 times the surface of the pipe cross section surface which is given in the chart "Pipe diameters of the surface pump suction lines". But it doesn't end here. It commands us to connect parallel, one more suction drain with same size, 2 meters away from each pump.

Even we use the smallest pump, suction drain surface must be greater than 1 square meter. When a user comes to suction surface, user must not cover more than 50% of the surface. Do not make suction from bottom main drains when the pool is in use. Even our smallest pump creates 0,8 bar vacuum when the suction line is closed. That means 1280 kg tensile force is applied to the person sucked by 40x40 cm suction main drain.

Please do not forget; by building non-standard drains with excuses like sale, nevermind and providing benefit will kill your own children and loved ones too.

**İBRAHİM HAKKI UYSAL**  
General Manager  
Mechanical Engineer

