



u-pvc fittings ve borular

u-pvc fittings and pipes



2026
Fiyat Listesi-Price List



NOZBART®
The best of the world...



PLASTİK VE MAKİNA KALIP SANAYİ VE TİCARET LİMİTED ŞİRKETİ

- * Farklı uygulamalar için yüksek kalite U-P.V.C'den mamul.
Made of high quality U-PVC material for diverse applications.
- * Tamamıyla termoplastik malzemeden mamul, korozyonsuz sağlıklı çalışma.
Made of thermoplastic material, working without corrosion
- * Ortam koşullarına ve mekanik etkilere üstün dayanım.
Excellent mechanical and environmental strength.
- * Yüzme havuzu, endüstriyel uygulamalar, arıtma sistemleri ve içme suyu sistemlerine uygun.
Ideally suited for swimming pool, industrial, water treatment or water distribution applications.
- * Metrik seriler ISO 727, EN 1452, DIN 8063 ve dişli seriler ISO R7, ISO 228/1, BS 21, DIN 2999 standartlarına uygun.
Metric series with ISO 727, EN 1452, DIN 8063 and threaded series with ISO R7, ISO 228/1, BS 21, DIN 2999.
- * Asitler dahil olmak üzere birçok kimyasal ile çalışma imkanı.
U-PVC fittings are resistant to a wide range of chemicals including acids.
- * Tamamıyla orjinal hammaddeden üretilmiş olup, geri dönüşüm (hurda) malzeme kullanılmamaktadır.
Our products is made completely from the original raw materials, recycling (waste) material does not contain.

U-P.V.C FITTINGS İÇİN AKIŞKAN SICAKLIĞINA BAĞLI KULLANIM BASINCI DİYAGRAMI
TEMPERATURE - PRESSURE DIAGRAM FOR U-PVC FITTINGS

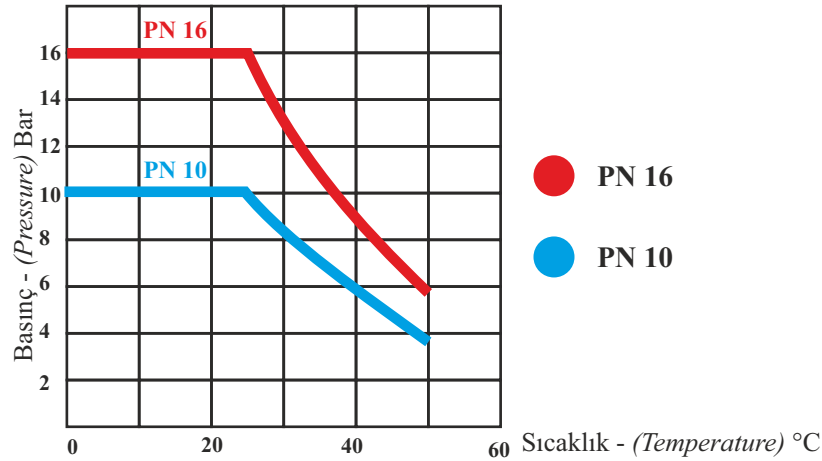

U-PVC FITTINGS İÇ VE BORU DIŞ TOLERANS GRAFİĞİ
U-PVC FITTINGS INTERNAL AND PIPE EXTERNAL TOLERANCE GRAPH

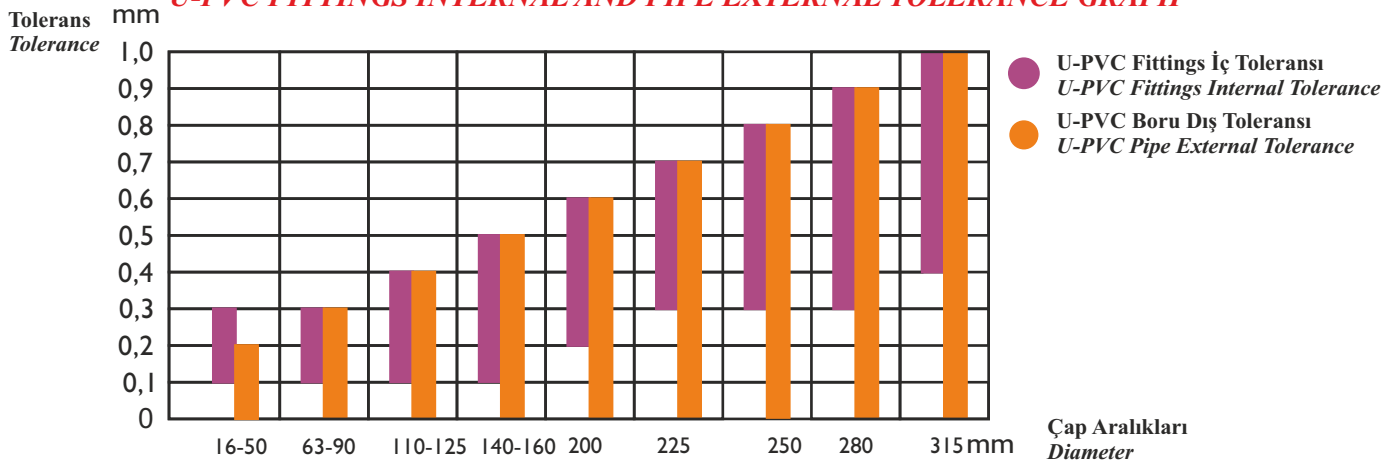

90° DERECE DİRSEK 90° ELBOW

- ✓ Metrik yapıştırma soketli
Metric female solvent socket

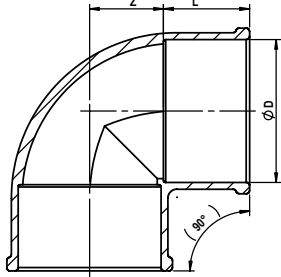

D		KOD CODE	Fiyatı Price (€)	PN	L	Z	Ambalaj Package
MM	INC						
20	1/2"	F90-020	0,36	16	16	11	650
25	3/4"	F90-025	0,41	16	19	13,5	300
32	1"	F90-032	0,62	16	22	17	170
40	1 1/4"	F90-040	1,04	16	26	21	80
50	1 1/2"	F90-050	1,05	16	31	26	150
63	2"	F90-063	1,31	16	38	32,5	70
75	2 1/2"	F90-075	2,63	16	44	38,5	40
90	3"	F90-090	3,62	16	51	46	30
110	4"	F90-110	6,11	16	61	56	30
125	4 1/2"	F90-125	9,16	16	69	63	20
140	5"	F90-140	13,56	16	76	71	15
160	6"	F90-160	17,47	16	86	81	12
200	7"	F90-200	42,60	10	106	100	8
225	8"	F90-225	61,91	10	119	113	6
250	9"	F90-250	164,01	10	131	188	2
280	10"	F90-280	253,47	10	147	210	2
315	12"	F90-315	295,36	10	164	236	1
355	14"	F90-355	462,21	10	184	-	1
400	16"	F90-400	566,58	10	206	-	1

Tüm ürünlerimiz enjeksiyondur.
All our products are manufactured by injection.

90° DERECE TEK TARAFI DİŞLİ DİRSEK 90° ELBOW (ONE SIDE THREADED)

- ✓ Metrik yapıştırma soketli
Metric female solvent socket
- ✓ BSP İç Dişli
BSP female thread socket

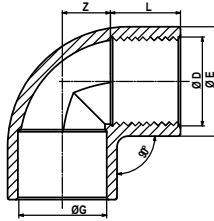

D	G	KOD CODE	Fiyatı Price (€)	PN	L	Z	E
MM	INC						
20	1/2"	F90-021	0,94	16	16	11	25
25	3/4"	F90-026	1,12	16	19	13,5	32
32	1"	F90-033	1,35	16	22	17	40
40	1 1/4"	F90-041	2,19	16	26	21	50

Tüm ürünlerimiz enjeksiyondur.
All our products are manufactured by injection.

90° DERECE İKİ TARAFI DİŞLİ DİRSEK 90° ELBOW (TWO SIDE THREADED)

- ✓ BSP İç Dişli
BSP female thread socket

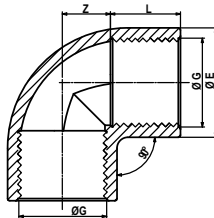

D	G	KOD CODE	Fiyatı Price (€)	PN	L	Z	E
MM	INC						
20	1/2"	F90-022	1,08	16	16	11	25
25	3/4"	F90-027	1,29	16	19	13,5	32
32	1"	F90-034	1,56	16	22	17	40
40	1 1/4"	F90-042	2,51	16	26	21	50

Tüm ürünlerimiz enjeksiyondur.
All our products are manufactured by injection.

45° DERECE DİRSEK

45° ELBOW

- ✓ Metrik yapıştırma soketli
Metric female solvent socket

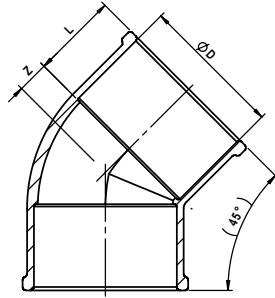

D MM	INC	KOD CODE	Fiyatı Price (€)	PN	L	Z	Ambalaj Package
25	3/4"	F45-025	0,41	16	19	6	400
32	1"	F45-032	0,62	16	22	7,5	200
40	1 1/4"	F45-040	1,00	16	26	9,5	100
50	1 1/2"	F45-050	1,01	16	31	11,5	180
63	2"	F45-063	1,19	16	38	14	85
75	2 1/2"	F45-075	2,49	16	44	16,5	50
90	3"	F45-090	3,37	16	51	19,5	30
110	4"	F45-110	5,68	16	61	23,5	38
125	4 1/2"	F45-125	8,73	16	69	27	25
140	5"	F45-140	12,50	16	76	30	18
160	6"	F45-160	17,40	16	86	34	12
200	7"	F45-200	37,35	10	106	42,5	10
225	8"	F45-225	61,20	10	119	48	8
250	9"	F45-250	141,72	10	131	58	2
280	10"	F45-280	231,18	10	147	62	2
315	12"	F45-315	244,24	10	164	66	1
355	14"	F45-355	425,29	10	184	-	1
400	16"	F45-400	508,36	10	206	-	1

Tüm ürünlerimiz enjeksiyondur.
All our products are manufactured by injection.

45° DERECE TEK TARAFI DİŞLİ DİRSEK

45° ELBOW (ONE SIDE THREADED)

- ✓ Metrik yapıştırma soketli
Metric female solvent socket
- ✓ BSP İç Dişli
BSP female thread socket

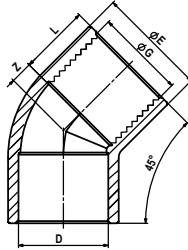

D MM	G INC	KOD CODE	Fiyatı Price (€)	PN	L	Z	E
20	1/2"	F45-021	0,95	16	16	5	25
25	3/4"	F45-026	1,14	16	19	6	32
32	1"	F45-033	1,36	16	22	7,5	40
40	1 1/4"	F45-041	2,20	16	26	9,5	50

Tüm ürünlerimiz enjeksiyondur.
All our products are manufactured by injection.

45° DERECE İKİ TARAFI DİŞLİ DİRSEK

45° ELBOW (TWO SIDE THREADED)

- ✓ BSP İç Dişli
BSP female thread socket

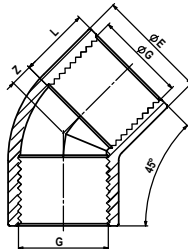

D MM	G INC	KOD CODE	Fiyatı Price (€)	PN	L	Z	E
20	1/2"	F45-022	1,09	16	16	5	25
25	3/4"	F45-027	1,31	16	19	6	32
32	1"	F45-034	1,56	16	22	7,5	40
40	1 1/4"	F45-042	2,56	16	26	9,5	50

Tüm ürünlerimiz enjeksiyondur.
All our products are manufactured by injection.

TE TEE

- ✓ Metrik yapıştırma soketli
Metric female solvent socket

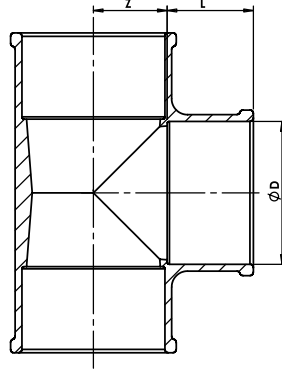

D		KOD	Fiyatı	PN	L	Z	Ambalaj
MM	INC	CODE	Price (€)				Package
20	1/2"	FTE-020	0,41	16	16	11	400
25	3/4"	FTE-025	0,48	16	19	13,5	200
32	1"	FTE-032	0,97	16	22	17	100
40	1 1/4"	FTE-040	1,18	16	26	21	50
50	1 1/2"	FTE-050	1,19	16	31	26	90
63	2"	FTE-063	1,70	16	38	32,5	50
75	2 1/2"	FTE-075	3,05	16	44	38,5	30
90	3"	FTE-090	4,69	16	51	46	20
110	4"	FTE-110	7,46	16	61	56	25
125	4 1/2"	FTE-125	11,22	16	69	63	16
140	5"	FTE-140	18,03	16	76	71	10
160	6"	FTE-160	24,99	16	86	81	8
200	7"	FTE-200	44,59	10	106	100	5
225	8"	FTE-225	83,50	10	119	113	4
250	9"	FTE-250	181,90	10	131	128	2
280	10"	FTE-280	286,27	10	147	144	2
315	12"	FTE-315	335,55	10	164	162	1
355	14"	FTE-355	678,76	10	184	-	1
400	16"	FTE-400	700,77	10	206	-	1

Tüm ürünlerimiz enjeksiyondur.
All our products are manufactured by injection.

TEK TARAFI DİŞLİ TE TEE (ONE SIDE THREADED)

- ✓ Metrik yapıştırma soketli
Metric female solvent socket
- ✓ BSP İç Dişli
BSP female thread socket

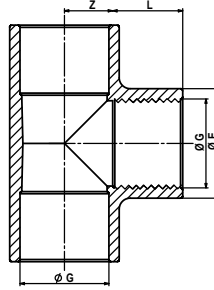

D	G	KOD	Fiyatı	PN	L	Z	E
MM	INC	CODE	Price (€)				
20	1/2"	FTE-021	1,32	16	16	11	25
25	3/4"	FTE-026	1,38	16	19	13,5	32
32	1"	FTE-033	2,02	16	22	17	40
40	1 1/4"	FTE-041	2,41	16	26	21	50

Tüm ürünlerimiz enjeksiyondur.
All our products are manufactured by injection.

İNEGAL TE
REDUCING TEE

✓ Metrik yapıştırma soketli
Metric female solvent socket

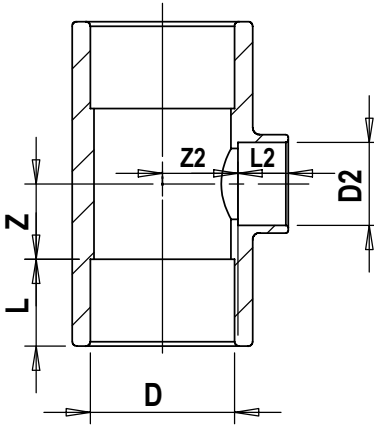

	D		D2	KOD CODE	Fiyatı Price (€)	PN	L	L2	Z	Z2
	MM	INC								
+	50	1 ½"	32	T50-32	1,68	16	31	22	28	28
+	63	2"	32	T63-32	3,32	16	38	22	35	26
+	63	2"	50	T63-50	3,14	16	38	31	35	34
+	75	2 ½"	50	T75-50	4,03	16	44	38	40	41
+	75	2 ½"	63	T75-63	4,26	16	44	38	40	41
+	90	3"	50	T90-50	5,74	16	51	38	46	55
+	90	3"	63	T90-63	6,04	16	51	38	46	55
+	90	3"	75	T90-75	6,25	16	51	38	46	55
+	110	4"	63	T110-63	8,24	16	61	38	56	65
+	110	4"	75	T110-75	8,66	16	61	44	56	65
+	110	4"	90	T110-90	9,09	16	61	51	56	65
+	125	4 ½"	63	T125-63	18,03	16	69	38	64	75
+	125	4 ½"	75	T125-75	17,75	16	69	44	64	83
+	125	4 ½"	90	T125-90	16,90	16	69	51	64	75
+	125	4 ½"	110	T125-110	18,32	16	69	61	64	75
+	140	5"	63	T140-63	25,99	16	76	66	72	97
+	140	5"	75	T140-75	25,70	16	76	44	72	91
+	140	5"	90	T140-90	24,78	16	76	51	72	75
+	140	5"	110	T140-110	22,58	16	76	61	72	74
+	160	6"	63	T160-63	32,80	16	86	38	81	105
+	160	6"	75	T160-75	32,52	16	86	44	81	99
+	160	6"	90	T160-90	31,81	16	86	51	81	93
+	160	6"	110	T160-110	42,32	16	86	61	81	81
+	160	6"	125	T160-125	37,63	16	86	69	81	105
+	200	7"	75	T200-75	60,07	10	106	44	107	147
+	200	7"	90	T200-90	59,36	10	106	51	107	141
+	200	7"	110	T200-110	59,93	10	106	61	107	131
+	200	7"	125	T200-125	56,09	10	106	69	107	115
+	200	7"	140	T200-140	54,25	10	106	76	107	110
+	200	7"	160	T200-160	92,59	10	106	86	107	106
+	225	8"	110	T225-110	104,65	10	108	60	120	119
+	225	8"	125	T225-125	103,66	10	108	67	120	162
+	225	8"	140	T225-140	101,81	10	119	76	120	157
+	225	8"	160	T225-160	99,12	10	119	86	120	119
+	225	8"	200	T225-200	90,74	10	119	106	114	126
+	250	9"	140	T250-140	268,66	10	131	76	132	191
+	250	9"	160	T250-160	265,97	10	131	86	132	169
+	250	9"	200	T250-200	257,59	10	131	106	132	157
+	250	9"	225	T250-225	247,51	10	131	119	132	144
+	280	10"	140	T280-140	365,51	10	147	76	152	226
+	280	10"	160	T280-160	362,81	10	147	86	152	204
+	280	10"	200	T280-200	354,43	10	147	106	152	192
+	280	10"	225	T280-225	344,35	10	147	119	152	179
+	280	10"	250	T280-250	317,51	10	147	131	152	167
+	315	12"	280	T315-280	409,39	10	164	147	168	184
+	355	14"	280	T355-280	636,73	10	184	147	196	242
+	355	14"	315	T355-315	631,47	10	184	164	196	224
+	400	16"	280	T400-280	872,31	10	206	147	214	283
+	400	16"	315	T400-315	842,49	10	206	164	214	265
+	400	16"	355	T400-355	827,58	10	206	164	214	237

+ Redüksiyon yapıştırılmadan verilecektir.
Reduction will not be glued.

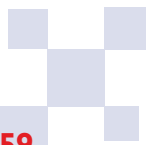

KÖR TAPA

CAP

- ✓ Metrik yapıştırma soketli
Metric female solvent socket

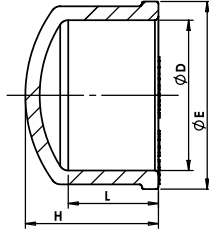

D		KOD CODE	Fiyatı Price (€)	PN	L	H	E	Ambalaj Package
MM	INC							
20	1/2"	FKT-020	0,24	16	16	24	27	1200
25	3/4"	FKT-025	0,30	16	19	29	32	800
32	1"	FKT-032	0,37	16	22	32	41	400
40	1 1/4"	FKT-040	0,44	16	26	40	54	250
50	1 1/2"	FKT-050	0,68	16	31	45	64	130
63	2"	FKT-063	0,81	16	38	56	79	60
75	2 1/2"	FKT-075	1,38	16	44	66	93	35
90	3"	FKT-090	1,80	16	51	76,5	110	20
110	4"	FKT-110	2,64	16	61	92	133	15
125	4 1/2"	FKT-125	4,26	16	69	115	144	32
140	5"	FKT-140	5,40	16	76	122	161,5	20
160	6"	FKT-160	9,88	16	86	140	185	12
200	7"	FKT-200	15,76	10	106	173	230	6
225	8"	FKT-225	26,41	10	119	196,5	260	10
250	9"	FKT-250	40,33	10	131	210	289	1
280	10"	FKT-280	56,80	10	147	240	320,5	1
315	12"	FKT-315	75,26	10	164	262	358	1
* 355	14"	FKT-355K	195,40	10	184	-	-	2
* 400	16"	FKT-400K	296,78	10	206	-	-	2

* Konfeksiyon / Hand made

MANŞON

MUFF

- ✓ Metrik yapıştırma soketli
Metric female solvent socket

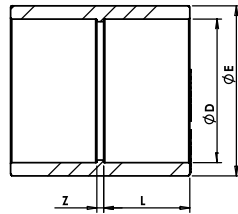

D		KOD CODE	Fiyatı Price (€)	PN	L	Z	E	Ambalaj Package
MM	INC							
20	1/2"	FMN-020	0,23	16	16	3	26	900
25	3/4"	FMN-025	0,28	16	19	3	31	450
32	1"	FMN-032	0,33	16	22	3	38	250
40	1 1/4"	FMN-040	0,51	16	26	3	48	140
50	1 1/2"	FMN-050	0,53	16	31	3	60	75
63	2"	FMN-063	0,85	16	38	3	75	35
75	2 1/2"	FMN-075	1,72	16	44	4	89	25
90	3"	FMN-090	2,17	16	51	5	106	15
110	4"	FMN-110	3,69	16	61	6	127	28
125	4 1/2"	FMN-125	4,54	16	69	6	140	36
140	5"	FMN-140	5,40	16	76	8	160	30
160	6"	FMN-160	8,09	16	86	8	187	20
200	7"	FMN-200	18,11	10	106	10	228	10
225	8"	FMN-225	28,97	10	119	10	252	6
250	9"	FMN-250	49,56	10	131	10	286	1
280	10"	FMN-280	78,46	10	147	10	320	1
315	12"	FMN-315	97,27	10	164	12	355	1
355	14"	FMN-355	143,70	10	184	-	-	1
400	16"	FMN-400	165,86	10	206	7	432	1

Tüm ürünlerimiz enjeksiyondur.

All our products are manufactured by injection.

FLANŞ
FLANGE

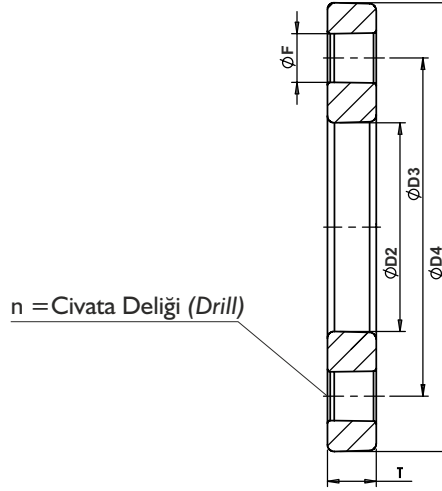

U-PVC

D		KOD CODE	Fiyatı Price (€)	PN	D2	D3	D4	T	F	n	Ambalaj Package
MM	INC										
20	1/2"	FFL-020	1,56	16	28	65	95	11	14	4	220
25	3/4"	FFL-025	1,56	16	34	75	105	12	14	4	170
32	1"	FFL-032	1,78	16	42	85	115	14	14	4	110
40	1 1/4"	FFL-040	2,06	16	51	100	140	15	18	4	75
50	1 1/2"	FFL-050	2,06	16	62	110	150	15,5	18	4	65
63	2"	FFL-063	2,49	16	78	125	165	18	18	4	42
75	2 1/2"	FFL-075	3,20	16	92	145	185	20	18	4	30
90	3"	FFL-090	3,55	16	110	160	200	22	18	8	72
110	4"	FFL-110	4,19	16	133	180	220	24	18	8	35
125	4 1/2"	FFL-125	5,47	16	150	210	250	26	18	8	30
140	5"	FFL-140	5,33	16	167	210	250	26	18	8	25
160	6"	FFL-160	6,96	16	190	240	285	28	22	8	20
200	7"	FFL-200	13,70	10	225	295	340	36	22	8	10
225	8"	FFL-225	13,70	10	250	295	340	36	22	8	10
250	9"	FFL-250	66,74	10	284	350	395	36	22	12	8
280	10"	FFL-280	56,66	10	307	350	395	36	22	12	1
315	12"	FFL-315	82,08	10	349	400	450	36	22	12	1
355	14"	FFL-355	298,20	10	388	460	505	38	22	16	1
400	16"	FFL-400	468,60	10	442	515	565	42	26	16	1

355 ve 400 mm kole ve flanşlar takım olarak satılmaktadır.

355 and 400 mm cole and flange are sold as a set.

Tüm ürünlerimiz enjeksiyondur.

All our products are manufactured by injection.

KOLE COLE

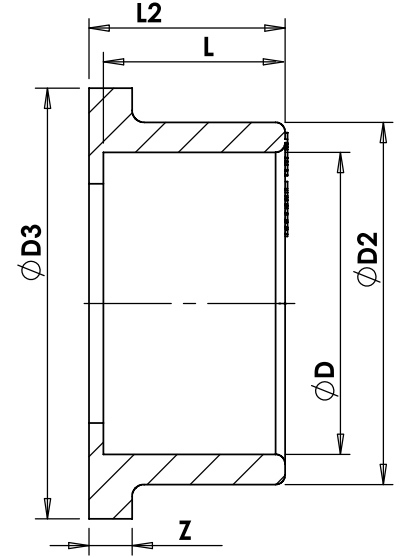

✓ Metrik ve BSP
 yapıştırma soketli
 Metric and BSP
 female solvent socket

U-PVC

METRİK-METRIC TSE / ISO / DIN		IMPERIAL BS / ANSI / ASTM			AUSTRALIA / NEW ZEALAND AS / NZS		DN mm	PN	FİYAT PRICE (€)	L	L2	Z	D2	D3
D mm	KOD CODE	D INCH	D mm	KOD CODE	D mm	KOD CODE								
20	FKL-020	1/2"	21.3	AFKL-020	21.3	AFKL-020	15	16	0,75	16	19	6	27	34
25	FKL-025	3/4"	26.9	AFKL-025	26.9	AFKL-025	20	16	0,75	19	21	7	33	41
32	FKL-032	1"	33.7	AFKL-032	33.7	AFKL-032	25	16	0,94	22	25	7	41	50
40	FKL-040	1 1/4"	42.4	AFKL-040	42.4	AFKL-040	32	16	1,07	26	29	8	50	61
50	FKL-050	1 1/2"	48.3	AFKL-050	48.3	AFKL-050	40	16	1,07	31	34	8	61	73
63	FKL-063	2"	60.3	AFKL-063	60.3	AFKL-063	50	16	1,09	38	41	9	76	90
75	FKL-075	2 1/2"	75.3	AFKL-075	75.3	AFKL-075	65	16	1,35	44	47	10	90	106
90	FKL-090	3"	88.9	AFKL-090	88.9	AFKL-090	80	16	1,79	51	56	11	108	125
110	FKL-110	4"	114.3	AFKL-110	114.3	AFKL-110	100	16	3,76	61	66	12	131	150
125	FKL-125	-	-	-	-	-	110	16	3,83	69	74	13	148	170
140	FKL-140	5"	140.3	AFKL-140	140.0	FKL-140	125	16	4,97	76	81	14	165	188
160	FKL-160	6"	168.3	AFKL-160	160.0	FKL-160	150	16	7,38	86	91	16	188	213
200	FKL-200	7"	193,7	AFKL-200	200.0	FKL-200	175	10	10,37	106	118	24	224	250
225	FKL-225	8"	219.1	AFKL-225	225.0	FKL-225	200	10	11,22	119	125	25	248	270
250	FKL-250	9"	244.5	AFKL-250	250.0	FKL-250	225	10	45,87	131	140	27	282	328
280	FKL-280	10"	273.0	AFKL-280	280.0	FKL-280	250	10	47,29	147	157	32	307	325
315	FKL-315	12"	323.9	AFKL-315	315.0	FKL-315	300	10	73,84	164	181	32	346	378
355	FKL-355	14"	355.6	AFKL-355	355.0	FKL-355	350	10	232,60	184	212	35	382	430
400	FKL-400	16"	406.4	AFKL-400	400.0	FKL-400	400	10	304,16	206	231	35	433	482

355 ve 400 mm kole ve flanşlar takım olarak satılmaktadır.

355 and 400 mm cole and flange are sold as a set.

Tüm ürünlerimiz enjeksiyondur.

All our products are manufactured by injection.

PP FLANŞ
PP FLANGE

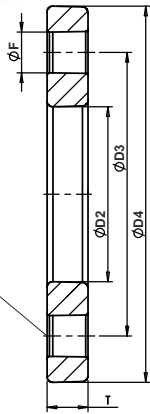
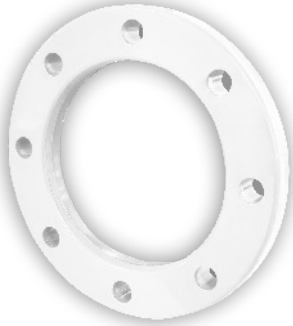

n = Civata Deliği (Drill)

D		KOD CODE	Fiyatı Price (€)	PN	D2	D3	D4	T	F	n	Ambalaj Package
MM	INC										
20	1/2"	FFL...-020	1,56	16	28	65	95	11	14	4	220
25	3/4"	FFL...-025	1,56	16	34	75	105	12	14	4	170
32	1"	FFL...-032	1,78	16	42	85	115	14	14	4	110
40	1 1/4"	FFL...-040	2,06	16	51	100	140	15	18	4	75
50	1 1/2"	FFL...-050	2,06	16	62	110	150	15,5	18	4	65
63	2"	FFL...-063	2,49	16	78	125	165	18	18	4	42
75	2 1/2"	FFL...-075	3,20	16	92	145	185	20	18	4	30
90	3"	FFL...-090	3,55	16	110	160	200	22	18	8	72
110	4"	FFL...-110	4,19	16	133	180	220	24	18	8	35
125	4 1/2"	FFL...-125	5,47	16	150	210	250	26	18	8	30
140	5"	FFL...-140	5,33	16	167	210	250	26	18	8	25
160	6"	FFL...-160	6,96	16	190	240	285	28	22	8	20
200	7"	FFL...-200	13,70	10	225	295	340	36	22	8	10
225	8"	FFL...-225	13,70	10	250	295	340	36	22	8	10
250	9"	FFL...-250	66,74	10	284	350	395	36	22	12	8
280	10"	FFL...-280	56,66	10	307	350	395	36	22	12	1
315	12"	FFL...-315	82,08	10	349	400	450	36	22	12	1
355	14"	FFL...-355	298,20	10	388	460	505	38	22	16	1
400	16"	FFL...-400	468,60	10	442	515	565	42	26	16	1

Tüm ürünlerimiz enjeksiyondur.

All our products are manufactured by injection.

- ✓ Renk seçimi için kod (...) noktalı yerlere (B-G-M-Y) harflerinden birini koyun.
Put one of these letters (B-G-M-Y) to the spaces with dots (...) for color choice.

PPRC KOLE
PPRC COLE

- ✓ Metrik ve BSP yapıştırma soketli
Metric and BSP female solvent socket

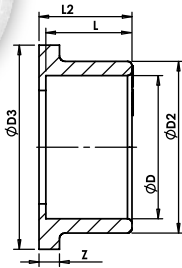

D		KOD CODE	Fiyatı Price (€)	PN	L	L2	Z	D2	D3
MM	INC								
20	1/2"	FKL...-020	0,75	16	16	19	6	27	34
25	3/4"	FKL...-025	0,75	16	19	21	7	33	41
32	1"	FKL...-032	0,94	16	22	25	7	41	50
40	1 1/4"	FKL...-040	1,07	16	26	29	8	50	61
50	1 1/2"	FKL...-050	1,07	16	31	34	8	61	73
63	2"	FKL...-063	1,09	16	38	41	9	76	90
75	2 1/2"	FKL...-075	1,35	16	44	47	10	90	106
90	3"	FKL...-090	1,79	16	51	56	11	108	125
110	4"	FKL...-110	3,76	16	61	66	12	131	150
125	4 1/2"	FKL...-125	3,83	16	69	74	13	148	170
140	5"	FKL...-140	4,97	16	76	81	14	165	188
160	6"	FKL...-160	7,38	16	86	91	16	188	213
200	7"	FKL...-200	10,37	16	106	118	24	224	250
225	8"	FKL...-225	11,22	10	119	125	25	248	270
250	9"	FKL...-250	45,87	10	131	140	27	274	328
280	10"	FKL...-280	47,29	10	147	157	32	307	325
315	12"	FKL...-315	73,84	10	164	181	32	346	378
355	14"	FKL...-355	232,60	10	184	212	35	382	430
400	16"	FKL...-400	304,16	10	206	231	35	433	482

Tüm ürünlerimiz enjeksiyondur.

All our products are manufactured by injection.

- ✓ Renk seçimi için kod (...) noktalı yerlere (B-G-M-Y) harflerinden birini koyun.
Put one of these letters (B-G-M-Y) to the spaces with dots (...) for color choice.

PE FLANŞ ADAPTÖRÜ PE FLANGE ADAPTOR

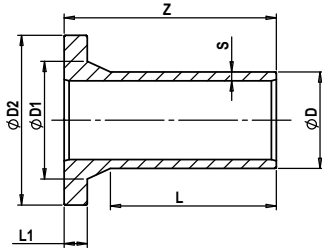
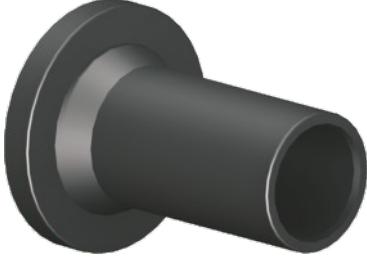

D		KOD CODE	Fiyatı Price (€)	PN	D1	D2	L	L1	Z	S	Ambalaj Package
MM	INC										
20	1/2"	PEKL-020	4,20	16	28	45	41	7	76	3,0	100
25	3/4"	PEKL-025	4,50	16	34	58	41	9	81	3,0	50
32	1"	PEKL-032	5,40	16	42	68	44	10	85	3,0	40
40	1 1/4"	PEKL-040	5,90	16	48	78	49	11	88	3,7	70
50	1 1/2"	PEKL-050	6,80	16	58	88	55	12	92	4,6	50
63	2"	PEKL-063	7,80	10	78	102	63	14	98	3,8	60
75	2 1/2"	PEKL-075	9,50	10	92	122	70	16	107	4,5	60
90	3"	PEKL-090	12,50	10	108	138	79	17	116	5,4	45
110	4"	PEKL-110	18,70	10	128	158	82	17	128	6,6	24
125	4 1/2"	PEKL-125	22,00	10	135	158	87	18	132	7,4	16
140	5"	PEKL-140	30,80	10	158	188	92	18	142	8,3	12
160	6"	PEKL-160	36,90	10	178	212	98	18	145	9,5	12
200	7"	PEKL-200	73,80	10	235	268	112	24	174	11,9	4
225	8"	PEKL-225	77,40	10	238	268	120	24	179	13,4	4
250	9"	PEKL-250	125,40	10	288	320	129	25	195	14,8	2
280	10"	PEKL-280	141,80	10	294	320	139	25	205	16,6	2
315	12"	PEKL-315	180,30	10	338	370	150	25	216	18,7	2
355	14"	PEKL-355	315,80	10	376	430	164	30	233	21,1	1
400	16"	PEKL-400	416,00	10	430	480	179	33	246	23,7	1

Tüm ürünlerimiz enjeksiyondur.
All our products are manufactured by injection.

PP KAPLI ÇELİK FLANŞ PP FLANGE WITH STEEL CORE

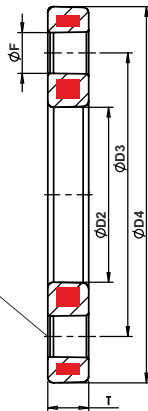

n = Civata Deliği (Drill)

D		KOD CODE	Fiyatı Price (€)	PN	D2	D3	D4	T	F	n	Ambalaj Package
MM	INC										
20	1/2"	PEFL-020	15,40	16	28	65	95	12	14	4	85
25	3/4"	PEFL-025	15,40	16	34	75	105	12	14	4	68
32	1"	PEFL-032	19,60	16	42	85	115	16	14	4	52
40	1 1/4"	PEFL-040	22,70	16	51	100	140	16	18	4	20
50	1 1/2"	PEFL-050	22,90	16	62	110	150	18	18	4	15
63	2"	PEFL-063	34,60	16	78	125	165	18	18	4	15
75	2 1/2"	PEFL-075	38,40	16	92	145	188	18	18	4	15
90	3"	PEFL-090	48,70	16	108	160	204	20	18	8	10
110	4"	PEFL-110	64,10	16	128	180	224	20	18	8	10
125	4 1/2"	PEFL-125	64,10	16	135	180	224	20	18	8	10
140	5"	PEFL-140	76,80	16	158	210	252	24	18	8	6
160	6"	PEFL-160	99,20	16	178	240	285	24	22	8	6
200	7"	PEFL-200	158,40	10	188	295	340	24	22	8	4
225	8"	PEFL-225	158,40	10	235	295	340	27	22	8	4
250	9"	PEFL-250	297,90	10	238	350	395	27	22	12	4
280	10"	PEFL-280	297,90	10	288	350	395	30	22	12	4
315	12"	PEFL-315	437,30	10	294	400	445	30	22	12	2
355	14"	PEFL-355	878,10	10	338	460	514	34	22	16	1
400	16"	PEFL-400	883,40	10	376	515	571	40	22	16	1

Tüm ürünlerimiz enjeksiyondur.
All our products are manufactured by injection.

KÖR FLANŞ
BLIND FLANGE

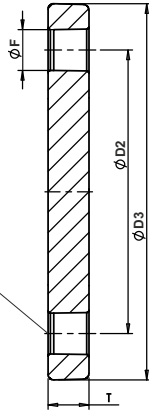

D		KOD CODE	FIYAT PRICE (€)	PN	D2	D3	T	F	n	AMBALAJ PACKAGE
MM	INC									
20	1/2"	FKF-020	4,47	16	65	95	11	14	4	250
25	3/4"	FKF-025	5,40	16	75	105	12	14	4	200
32	1"	FKF-032	6,25	16	85	115	14	14	4	120
40	1 1/4"	FKF-040	7,24	16	100	140	15	18	4	100
50	1 1/2"	FKF-050	8,66	16	110	150	16	18	4	30
63	2"	FKF-063	9,59	16	125	165	18	18	4	25
75	2 1/2"	FKF-075	10,79	16	145	185	20	18	4	20
90	3"	FKF-090	11,36	16	160	200	22	18	8	15
110	4"	FKF-110	11,64	16	180	220	24	18	8	12
125	4 1/2"	FKF-125	14,91	16	210	250	26	18	8	30
140	5"	FKF-140	14,91	16	210	250	26	18	8	25
160	6"	FKF-160	21,02	16	240	285	28	22	8	20
200	7"	FKF-200	56,09	10	295	340	36	22	8	7
225	8"	FKF-225	56,09	10	295	340	36	22	8	7
250	9"	FKF-250	177,50	10	350	395	36	22	12	8
280	10"	FKF-280	177,50	10	350	395	36	22	12	1
315	12"	FKF-315	234,30	10	400	450	36	22	12	1
355	14"	FKF-355	660,30	10	460	505	38	22	16	1
400	16"	FKF-400	702,90	10	515	565	42	26	16	1

Tüm ürünlerimiz enjeksiyondur.
All our products are manufactured by injection.

KURUVA
CROSS

- ✓ Metrik yapıştırma soketli
Metric female solvent socket

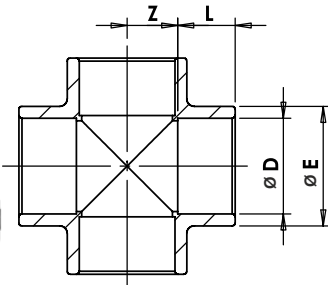

D		KOD CODE	FIYATI PRICE (€)	PN	L	Z	E	AMBALAJ PACKAGE
MM	INC							
25	3/4"	FKR-025	3,28	16	19	13,5	32	150
32	1"	FKR-032	3,35	16	22	17	40	80
40	1 1/4"	FKR-040	3,83	16	26	21	50	45
50	1 1/2"	FKR-050	4,54	16	31	26	61	60
63	2"	FKR-063	7,38	16	38	32,5	75	30
75	2 1/2"	FKR-075	8,72	16	44	38,5	89	20
90	3"	FKR-090	11,08	16	51	46	107	12
110	4"	FKR-110	21,58	16	61	56	129	7
140	5"	FKR-140	72,56	16	76	71	-	4
160	6"	FKR-160	93,29	16	86	86	-	3
* 200	7"	FKR-200	205,76	10	106	106	-	3
* 225	8"	FKR-225	234,02	10	118	114	-	3
* 250	9"	FKR-250	375,73	10	131	132	-	1
* 280	10"	FKR-280	518,87	10	146	152	-	1
* 315	12"	FKR-315	627,07	10	163	168	-	1
* 355	14"	FKR-355	719,94	10	193	196	-	1
* 400	16"	FKR-400	954,24	10	216	214	-	1

* Konfeksiyon / Hand made

U-PVC BETON GEÇİŞ FLANŞI *U-PVC WALL CROSS FLANGES*

D		KOD CODE	FİYATI PRICE (€)	PN	D2	H
MM	INC					
50	1 ½"	FBG-050	0,53	16	85	26
63	2"	FBG-063	0,55	16	100	31,5
75	2 ½"	FBG-075	0,75	16	115	37
90	3"	FBG-090	1,01	16	133	42
110	4"	FBG-110	1,19	16	160	50,5
125	4 ½"	FBG-125	1,85	16	180	56,5
140	5"	FBG-140	2,24	16	200	62,5
160	6"	FBG-160	2,54	16	225	71
200	7"	FBG-200	4,67	10	272	87
225	8"	FBG-225	11,22	10	303	97
250	9"	FBG-250	22,15	10	334	107
280	10"	FBG-280	28,40	10	400	107
315	12"	FBG-315	37,06	10	400	107
355	14"	FBG-355	52,54	10	485	107
400	16"	FBG-400	66,74	10	485	107

Tüm ürünlerimiz enjeksiyondur.
All our products are manufactured by injection.

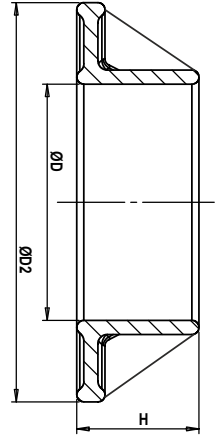

- ✓ Metrik yapıştırma soketli, uzun yapıştırma boyu
Metric female solvent socket, extra long bonding length
- ✓ Yüksek kalite plastik enjeksiyon
High quality plastic injection
- ✓ Dönmeyi engelleyen, sağlamlık kazandıran destekler
Special supports that prevent rotation and give stability
- ✓ Sızdırmazlık sağlayan özel pürüzlü yüzey
Special rough surface for leakproofing
- ✓ Ortam koşullarına ve mekanik etkilere üstün dayanım
Excellent mechanical and environmental strength

İÇ DİŞLİ ADAPTÖR
INTERIOR THREADED ADAPTORS

- ✓ BSP iç dişli ve metrik yapıştırma soketli
BSP female threaded and metric female solvent socket

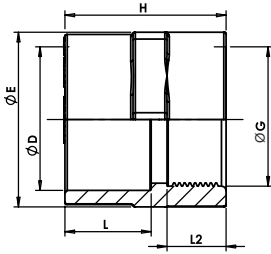

D		KOD CODE	FİYAT PRICE (€)	PN	L	L2	H	G	E	AMBALAJ PACKAGE
MM	INC									
20	1/2"	FAD-020	0,33	16	16	15	37,5	1/2"	27	750
25	3/4"	FAD-025	0,37	16	19	16,3	37,8	3/4"	32	500
32	1"	FAD-032	0,60	16	22	19	46	1"	43	200
40	1 1/4"	FAD-040	0,82	16	26	21,4	49,9	1 1/4"	50	150
50	1 1/2"	FAD-050	1,19	16	31	21,5	59,5	1 1/2"	63	75
63	2"	FAD-063	1,70	16	38	26	71	2"	77	40
75	2 1/2"	FAD-075	2,56	16	44	30,5	81,5	2 1/2"	94	25
90	3"	FAD-090	3,20	16	51	33,5	91,5	3"	108	20
110	4"	FAD-110	5,11	16	61	39,3	110,3	4"	125	24
125	4 1/2"	FAD-125	8,38	16	69	44	147	4 1/2"	140	18
140	5"	FAD-140	14,77	16	76	49	151	5"	160	15
160	6"	FAD-160	21,87	16	86	66	179	6"	185	12
200	7"	FAD-200	63,62	10	106	70	224	7"	218	8
225	8"	FAD-225	99,12	10	119	65	250	8"	244	5
250	9"	FAD-250	117,58	10	131	109	340	9"	270	1

Tüm ürünlerimiz enjeksiyondur.
All our products are manufactured by injection.

DIŞ DİŞLİ ADAPTÖR
EXTERIOR THREADED ADAPTORS

- ✓ BSP dış dişli ve metrik yapıştırma soketli
BSP male threaded and metric female solvent socket

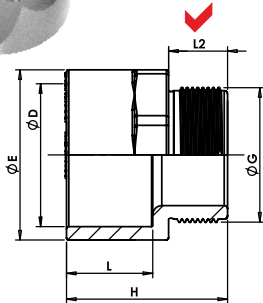

D		KOD CODE	FİYAT PRICE (€)	PN	L	L2	H	G	E	AMBALAJ PACKAGE
MM	INC									
20	1/2"	FDD-020	0,31	16	16	15	42	1/2"	25	750
25	3/4"	FDD-025	0,40	16	19	16,3	46,3	3/4"	32	450
32	1"	FDD-032	0,48	16	22	19,1	45,1	1"	40	300
40	1 1/4"	FDD-040	0,94	16	26	21,4	62,40	1 1/4"	50	120
50	1 1/2"	FDD-050	1,21	16	31	21,5	58,5	1 1/2"	60	100
✓ 50	1 1/2"	FDDU-050	1,79	16	31	34	71	1 1/2"	60	200
✓ 63	2"	FDD-063	1,82	16	38	26	71	2"	75	50
✓ 63	2"	FDDU-063	4,05	16	38	44	89	2"	75	45
✓ 75	2 1/2"	FDD-075	2,49	16	44	30,2	83	2 1/2"	90	40
✓ 75	2 1/2"	FDDU-075	4,54	16	44	50,5	103	2 1/2"	90	60
✓ 90	3"	FDD-090	4,40	16	51	33,5	94	3"	106	25
✓ 90	3"	FDDU-090	7,53	16	51	57	117,5	3"	106	35
✓ 110	4"	FDD-110	5,54	16	61	39,5	112	4"	129,5	12
✓ 110	4"	FDDU-110	8,95	16	61	70	142,5	4"	129,5	20
125	4 1/2"	FDD-125	13,49	16	69	44	-	-	-	1
140	5"	FDD-140	16,19	16	76	-	-	-	-	1
160	6"	FDD-160	24,99	16	86	-	-	-	-	1
200	7"	FDD-200	62,48	10	106	-	-	-	-	1
225	8"	FDD-225	89,32	10	119	-	-	-	-	1

Tüm ürünlerimiz enjeksiyondur.
All our products are manufactured by injection.

- ✓ Ekstra Diş Uzunluğu
Extra Long Thread

NİPEL NIPPLE

- ✓ BSP dış dişli
BSP male threaded

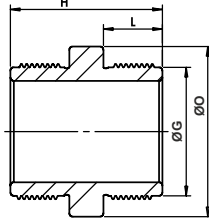

D INC	KOD CODE	FİYAT PRICE (€)	PN	L	H	G	O	AMBALAJ PACKAGE
1/2"	FNP-020	0,45	16	15	42	1/2"	24	900
3/4"	FNP-025	0,53	16	16,3	44	3/4"	30	550
1"	FNP-032	0,60	16	19,1	50	1"	36	300
1 1/4"	FNP-040	0,89	16	21,4	58	1 1/4"	46	180
1 1/2"	FNP-050	1,07	16	21,4	58	1 1/2"	50	140
2"	FNP-063	1,35	16	25,7	66	2"	65	70
2 1/2"	FNP-075	2,27	16	30,2	78	2 1/2"	80	35
3"	FNP-090	3,27	16	33,3	85	3"	95	70
4"	FNP-110	3,55	16	39,3	96	4"	120	40
4 1/2"	FNP-125	13,35	16	-	-	4 1/2"	-	1
5"	FNP-140	15,05	16	-	-	5"	-	1
6"	FNP-160	22,15	16	-	-	6"	-	1
7"	FNP-200	31,24	10	-	-	7"	-	1

Tüm ürünlerimiz enjeksiyondur.
All our products are manufactured by injection.

REDÜKSİYON REDUCTIONS

- ✓ Metrik iç ve dış yapıştırma soketli
Metric male and female solvent socket

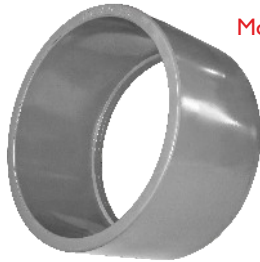

Model A



Model B

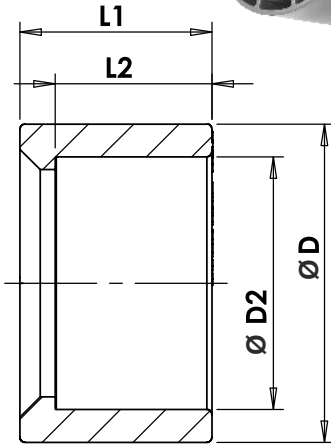

D		KOD CODE	FİYAT PRICE (€)	PN	L1	L2	D2	MODEL	AMBALAJ PACKAGE
MM	INC								
25	3/4"	25-20	0,16	16	19	16	20	A	1800
32	1"	32-20	0,24	16	22	16	20	A	950
32	1"	32-25	0,16	16	22	19	25	A	950
40	1 1/4"	40-25	0,34	16	26	19	25	B	500
40	1 1/4"	40-32	0,20	16	26	22	32	A	500
50	1 1/2"	50-32	0,48	16	31	22	32	B	250
50	1 1/2"	50-40	0,23	16	31	26	40	A	250
63	2"	63-32	0,85	16	38	22	32	B	130
63	2"	63-40	0,99	16	38	26	40	A	130
63	2"	63-50	0,57	16	38	31	50	B	130
75	2 1/2"	75-50	0,88	16	44	31	50	B	75
75	2 1/2"	75-63	0,58	16	44	38	63	A	75
90	3"	90-50	1,63	16	51	31	50	B	45
90	3"	90-63	1,04	16	51	38	63	B	45
90	3"	90-75	0,85	16	51	44	75	A	45
110	4"	110-63	2,56	16	61	38	63	B	28
110	4"	110-75	2,41	16	61	44	75	B	28
110	4"	110-90	2,09	16	61	51	90	A	28
125	4 1/2"	125-90	3,34	16	69	51	90	B	45
125	4 1/2"	125-110	1,85	16	69	61	110	A	45
140	5"	140-90	5,23	16	76	51	90	B	35
140	5"	140-110	3,48	16	76	61	110	B	35
140	5"	140-125	2,27	16	76	69	125	A	35
160	6"	160-90	7,81	16	86	51	90	B	20
160	6"	160-110	5,54	16	86	61	110	B	20
160	6"	160-140	2,70	16	86	76	140	A	20
200	7"	200-160	8,73	16	106	86	160	B	12
225	8"	225-200	10,51	16	119	106	200	A	8
250	9"	250-225	26,84	16	131	119	225	A	
280	10"	280-250	34,22	16	147	131	250	A	
315	12"	315-280	51,55	16	164	147	280	A	
355	14"	355-280	100,00	16	184	147	280	A	
355	14"	355-315	95,00	16	184	164	315	A	
400	16"	400-355	112,00	16	206	184	355	A	

Tüm ürünlerimiz enjeksiyondur.
All our products are manufactured by injection.

U-PVC GÖZETLEME CAMLARI
U-PVC SIGHT GLASSES

- ✓ Civataların görüş alanını bölüp daraltmadığı uzun ve geniş görüş alanı
The wide and extended eyesight which is not constricted by bolts
- ✓ Yüksek kalite plastikten 20 mm'den 315 mm'ye tüm çaplarda
Made of high quality plastic and in all diameters from 20 mm to 315 mm
- ✓ Kendinden rakorlu özel tasarım
Special design with unions built in
- ✓ Net görünüm sağlayan tam saydam sararmaz pleksiglas malzeme
Completely transparent and plexiglass material that enables a clear vision
- ✓ Sağlam, dayanıklı ve kaliteli
Durable, heavy-duty and high quality
- ✓ Montajlı tesisattan kolaylıkla sökülüp takılma imkanı
It can be mounted and demounted easily from an assembled installation

Model A. Rakorlu
Model A. with Unions

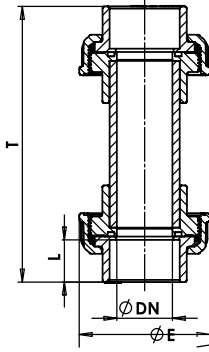

D		KOD CODE	FİYAT PRICE (€)	PN	DN	L	T	E
MM	INC							
20	1/2"	FGK-020	16,47	10	15	16	139	54
25	3/4"	FGK-025	17,89	10	20	19	145	60
32	1"	FGK-032	19,45	10	25	22	157	68
40	1 1/4"	FGK-040	20,87	10	32	26	183	83
50	1 1/2"	FGK-050	22,44	10	40	31	203	97
63	2"	FGK-063	25,42	10	50	38	228	118
75	2 1/2"	FGK-075	64,18	10	65	44	252	143
90	3"	FGK-090	86,48	10	80	51	282	178
110	4"	FGK-110	95,42	10	100	61	335	203

Tüm ürünlerimiz enjeksiyondur.
All our products are manufactured by injection.

Model B. Çıplak
Model B. Naked

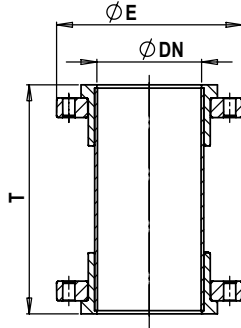

D		KOD CODE	FİYAT PRICE (€)	PN	DN	T	E
MM	INC						
125	4 1/2"	FGC-125	104,37	10	110	295	250
140	5"	FGC-140	104,37	10	125	295	250
160	6"	FGC-160	143,14	10	150	340	285
200	7"	FGC-200	196,81	10	175	354	340
225	8"	FGC-225	196,81	10	200	354	340
250	9"	FGC-250	447,30	10	225	418	395
280	10"	FGC-280	447,30	10	225	418	395
315	12"	FGC-315	680,18	10	300	534	465

Tüm ürünlerimiz enjeksiyondur.
All our products are manufactured by injection.

Model B. Komple
Model B. Complete

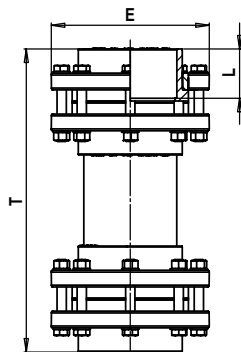

D		KOD CODE	FİYAT PRICE (€)	PN	DN	L	T	E
MM	INC							
125	4 1/2"	FGK-125	164,01	10	110	69	443	250
140	5"	FGK-140	164,01	10	125	76	457	250
160	6"	FGK-160	226,49	10	150	86	522	285
200	7"	FGK-200	310,27	10	175	106	590	340
225	8"	FGK-225	310,27	10	200	119	604	340
250	9"	FGK-250	718,52	10	225	131	698	395
280	10"	FGK-280	718,52	10	225	131	732	395
315	12"	FGK-315	1216,94	10	300	164	896	465

Tüm ürünlerimiz enjeksiyondur.
All our products are manufactured by injection.

PRIZ KOLYE SOCKET COLLAR

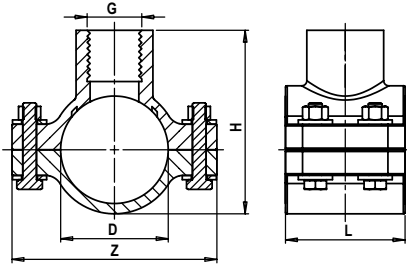
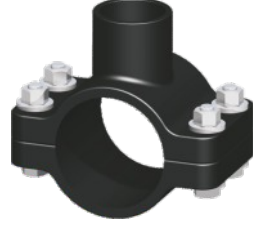

D		G	KOD CODE	FİYATI PRICE (€)	PN	Z	H	L
MM	INC							
32	1"	1/4"	FPK-032	*	10	-	-	-
32	1"	3/4"	FPK-033	*	10	-	-	-
40	1 1/4"	1/2"	FPK-040	*	10	-	-	-
40	1 1/4"	3/4"	FPK-041	*	10	-	-	-
40	1 1/4"	1"	FPK-042	*	10	-	-	-
50	1 1/2"	1/2"	FPK-050	*	10	-	-	-
50	1 1/2"	3/4"	FPK-051	*	10	-	-	-
50	1 1/2"	1"	FPK-052	*	10	-	-	-
63	2"	1/2"	FPK-063	*	10	121	105	82
63	2"	3/4"	FPK-064	*	10	121	105	82
63	2"	1"	FPK-065	*	10	121	105	82
75	2 1/2"	1/2"	FPK-075	*	10	133	120	88
75	2 1/2"	3/4"	FPK-076	*	10	133	120	88
75	2 1/2"	1"	FPK-077	*	10	133	120	88
90	3"	1/2"	FPK-090	*	10	147	142	88
90	3"	3/4"	FPK-091	*	10	147	142	88
90	3"	1"	FPK-092	*	10	147	142	88
110	4"	1/2"	FPK-110	*	10	168	162	105
110	4"	3/4"	FPK-111	*	10	168	162	105
110	4"	1"	FPK-112	*	10	168	162	105

Tüm ürünlerimiz enjeksiyondur.
All our products are manufactured by injection.

U-PVC KELEPÇELER U-PVC PIPE CLIPS



MALZEME CİNSİ DESCRIPTION	KOD NO CODE NO	FİYATI €/AD. PRICE €/Unit	AMBALAJ PACKAGE
20 mm. Kelepçe - Clip	FBK-020	0,10	500
25 mm. Kelepçe - Clip	FBK-025	0,11	400
32 mm. Kelepçe - Clip	FBK-032	0,17	300
40 mm. Kelepçe - Clip	FBK-040	0,23	200
50 mm. Kelepçe - Clip	FBK-050	0,33	100
63 mm. Kelepçe - Clip	FBK-063	0,68	200
75 mm. Kelepçe - Clip	FBK-075	0,80	100
90 mm. Kelepçe - Clip	FBK-090	1,08	100
110 mm. Kelepçe - Clip	FBK-110	1,12	100
125 mm. Kelepçe - Clip	FBK-125	2,24	100
160 mm. Kelepçe - Clip	FBK-160	3,91	50
200 mm. Kelepçe - Clip	FBK-200	5,81	30

Tüm ürünlerimiz enjeksiyondur.
All our products are manufactured by injection.

AVRUPADAN İTHAL
U-PVC YAPIŞTIRICILAR VE TEMİZLEYİCİ
IMPORTED FROM EUROPE
U-PVC ADHESIVE AND CLEANING SOLVENT



MALZEME CİNSİ DESCRIPTION	KOD CODE	FİYATI PRICE (€)
U-PVC Yapıştırıcı (Pegafor-1 kg.) U-PVC Adhesive (Pegafor-1 kg.)	YAP-105	37,00
U-PVC Yapıştırıcı fırçalı (Pegafor-1/2 kg.) U-PVC Adhesive with brush (Pegafor-1/2 kg.)	YAP-106	20,31
U-PVC Yapıştırıcı fırçalı (Pegafor-1/4 kg.) U-PVC Adhesive with brush (Pegafor-1/4 kg.)	YAP-110	12,50
U-PVC Yapıştırıcı (Pegafor-1/8 kg.) U-PVC Adhesive (Pegafor-1/8 kg.)	YAP-111	6,11

Basınçlı sistemler için U-PVC yapıştırıcı.
Solvent cement for U-PVC pressure systems.
Kıvamlı yapısı ile boşluğu komple doldurur, akıntı yapmaz.
Its high resin content gives it a high gap-filling capacity.
CE işaretiyle, Avrupa Birliği direktiflerine uygundur.
CE marking, the marking certifies that a product has met European Directives.

KAYNAK ÇUBUĞU
WELDING ROD



MALZEME CİNSİ DESCRIPTION	KOD CODE	FİYATI PRICE (€)
U-PVC Kaynak Çubuğu (Ø3-10 mm) /kg U-PVC Welding Rod (Ø3-10 mm) /kg	YAP-108	*

U-PVC BORULAR *U-PVC PIPES*

DIŞ ÇAP EXTERIOR DIAMETER	İNÇ INCHES	U-PVC BORULAR U-PVC PIPES			
		PN 6	PN 10	PN 16	ZONDER
20	1/2"	-	-	PN16-020	ZON-020
25	3/4"	-	PN10-025	PN16-025	ZON-025
32	1"	-	PN10-032	PN16-032	ZON-032
40	1 1/4"	PN06-040	PN10-040	PN16-040	ZON-040
50	1 1/2"	PN06-050	PN10-050	PN16-050	ZON-050
63	2"	PN06-063	PN10-063	PN16-063	ZON-063
75	2 1/2"	PN06-075	PN10-075	PN16-075	ZON-075
90	3"	PN06-090	PN10-090	PN16-090	ZON-090
110	4"	PN06-110	PN10-110	PN16-110	ZON-110
125	4 1/2"	PN06-125	PN10-125	PN16-125	ZON-125
140	5"	PN06-140	PN10-140	PN16-140	ZON-140
160	6"	PN06-160	PN10-160	PN16-160	ZON-160
200	7"	PN06-200	PN10-200	PN16-200	ZON-200
225	8"	PN06-225	PN10-225	PN16-225	ZON-225
250	9"	PN06-250	PN10-250	PN16-250	ZON-250
280	10"	PN06-280	PN10-280	PN16-280	-
315	12"	PN06-315	PN10-315	PN16-315	-
355	14"	PN06-355	PN10-355	PN16-355	-
400	16"	PN06-400	PN10-400	PN16-400	-



Lütfen fiyat sorunuz. / Please consult us.

ISO 727-1

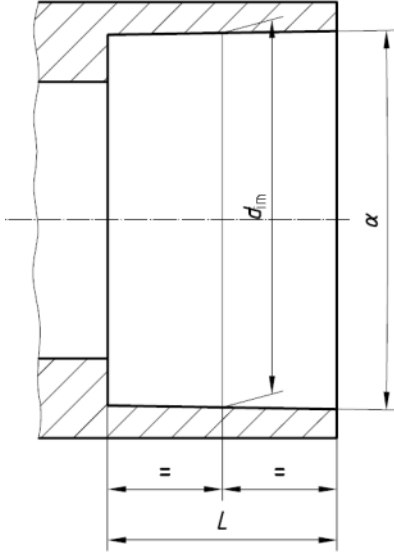

a) Soket / Socket

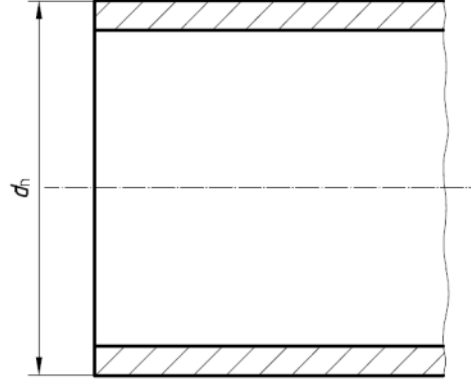

b) Boru / Pipe

U-PVC Fittings Ölçü Tablosu
U-PVC Fittings Dimension Table

Nominal dış çap Nominal outside diameter d_n	Minimum soket uzunluğu Minimum socket length L	Soket orta noktada iç çapı ortalaması Mean inside diameter at mid-point of socket depth d_m		Yuvarlaklıktan Sapma (Ovalik) Out of roundness max.
		min.	max.	
10	12	10,1	10,3	0,25
12	12	12,1	12,3	0,25
16	14	16,1	16,3	0,25
20	16	20,1	20,3	0,25
25	18,5	25,1	25,3	0,25
32	22	32,1	32,3	0,25
40	26	40,1	40,3	0,25
50	31	50,1	50,3	0,3
63	37,5	63,1	63,3	0,4
75	43,5	75,1	75,3	0,5
90	51	90,1	90,3	0,6
110	61	110,1	110,4	0,7
125	68,5	125,1	125,4	0,8
140	76	140,2	140,5	0,9
160	86	160,2	160,5	1
180	96	180,2	180,6	1,1
200	106	200,2	200,6	1,2
225	118,5	225,3	225,7	1,4
250	131	250,3	250,8	1,5
280	146	280,3	280,9	1,7
315	163,5	315,4	316	1,9
355	183,5	355,5	356,2	2,2
400	206	400,5	401,5	2,4

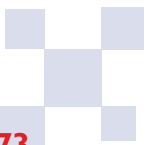

TÜM

**TÜV
CERT**
DIN EN ISO 9001:2015
Zertifikat 15 100 52993



EAC

CE



* UHE Kurucu Üyesidir.*

KELEPÇE VE DESTEK KULLANIMI *PIPE CLIPS AND BRACKET USE*

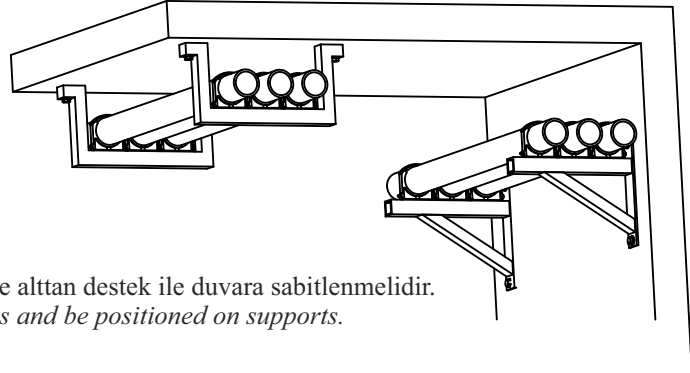

U-PVC borularda kapaklı kelepçe kullanılmalı ve alttan destek ile duvara sabitlenmelidir.
U-PVC pipes must be fixed using slip on brackets and be positioned on supports.

KELEPÇE VE YAPIŞTIRICI MİKTARI *PIPE CLIPS AND CEMENT*

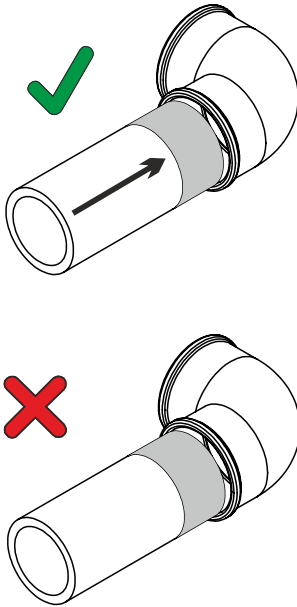

D		Kelepçe Aralıkları Bracket Spacing (m)			Bir litre yapıştırıcı ile yapıştırma sayısı Recommended joints per litre of cement
		20 °C	30 °C	40 °C	
MM	INC				
20	1/2"	0,90	0,80	0,60	375
25	3/4"	1,00	0,90	0,70	300
32	1"	1,10	0,95	0,75	250
40	1 1/4"	1,20	1,10	0,90	200
50	1 1/2"	1,30	1,20	1,00	110
63	2"	1,40	1,30	1,10	80
75	2 1/2"	1,50	1,40	1,20	55
90	3"	1,60	1,50	1,30	40
110	4"	1,90	1,80	1,60	25
125	4 1/2"	2,10	2,00	1,85	22
140	5"	2,20	2,10	1,90	18
160	6"	2,30	2,20	2,00	11
200	7"	2,60	2,45	2,30	7
225	8"	2,60	2,45	2,30	5
250	9"	2,80	2,70	2,55	4
280	10"	3,20	3,00	2,85	3
315	12"	3,60	3,40	3,20	2

FLANŞ SIKMA SIRASI *FLANGE TIGHTENING SEQUENCE*

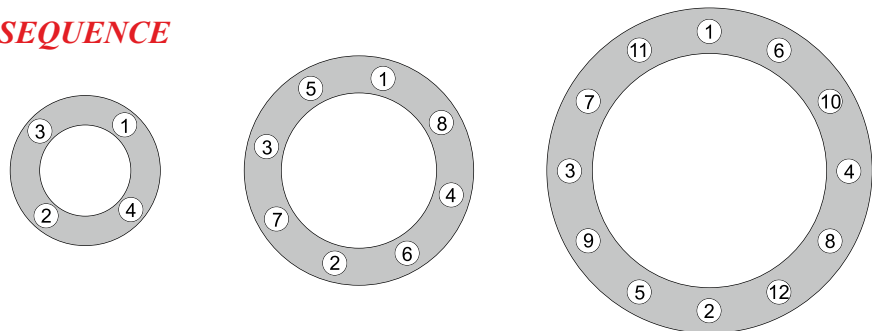

YÜZME HAVUZU İÇİN BORU SEÇİMİ (PN 10)
SWIMMING POOL PIPE SELECTION GUIDE (PN 10)

Boru Dış Çapı Nominal Diameter	Boru İç Çapı Inside Diameter	Debi (Flow) m ³ /saat (m ³ /hour)			
		Emiş Hattı (Suction Line) V= 1,5 m/sn	Basma Hattı (Discharge Line) V= 2,5 m/sn	% 1,5 Eğimli Taşma (% 1,5 Sloping Line) V= 0,75 m/sn	Kollektör (Collector) V= 0,5 m/sn
mm	mm	TON / SAAT	TON / SAAT	TON / SAAT	TON / SAAT
40	36	5.5	9.2	2.7	1.8
50	45	8.5	14.3	4.3	2.8
63	57	14	23	6.9	4.6
75	67	19	31.7	9.5	6.3
90	81	27.8	46.4	13.9	9.3
110	100	42.4	70.7	21.2	14
125	113	54	90.3	27	18
140	126	67.3	112	33.7	22.4
160	145	89.2	149	44.6	30
200	181	139	231.6	69.5	46.3
225	203	175	291.3	87.4	58.3
250	226	216.6	361	108.3	72.2
280	253	271.5	452.5	135.7	90.5
315	285	344.5	574	172.2	115
355	327	453.5	756	227	151
400	362	556	926.3	278	185.3

Debi (Flow) m³/saat (m³/hour) = $\rho \times D^2 / 4 \times V \times 3600 = 2827,43 \times D^2 \times V$ (m³/saat) (m³/hour)

D = Boru İç Çapı (Nominal Diameter) m

V = Akış Hızı (Velocity) m/sn

Akış Hızı Velocity m/sn	Emiş Hattı (Suction Line)	V= 1,5 m/sn
	Basma Hattı (Discharge Line)	V= 2,5 m/sn
	% 1,5 Eğimli taşma ana arteli (% 1,5 Sloping Line)	V= 0,75 m/sn
	Kollektör (Collector)	V= 0,5 m/sn

FITTINGS AKIŞ KAYBINA EŞDEĞER BORU UZUNLUĞU HESABI
CALCULATION OF FITTINGS FLOW LOSS EQUIVALENT PIPE LENGTH

L (Eş Değer Boru Uzunluğu (m)) = K (Kayıp Katsayısı) x DN (Nominal Çap (mm))

L (Equivalent Pipe Length (in meters)) = K (Loss Coefficient) x DN (Fittings Internal Diameter (mm))

FİTTİNGS (FITTINGS)	K
90° Dirsek (Elbow)	0,030
45° Dirsek (Elbow)	0,014
Te (Düz Tarafı) (Straight Through)	0,012
Te (Dönüş Tarafı) (Side Branch)	0,060
Redüksiyon (Reducing Bush) (Her kademe için) (Per Size)	0,150

20 °C U-PVC BORULARDA BASINÇ KAYBI NOMOGRAM PRESSURE LOSSES ON U-PVC PIPES NOMOGRAM AT 20°C

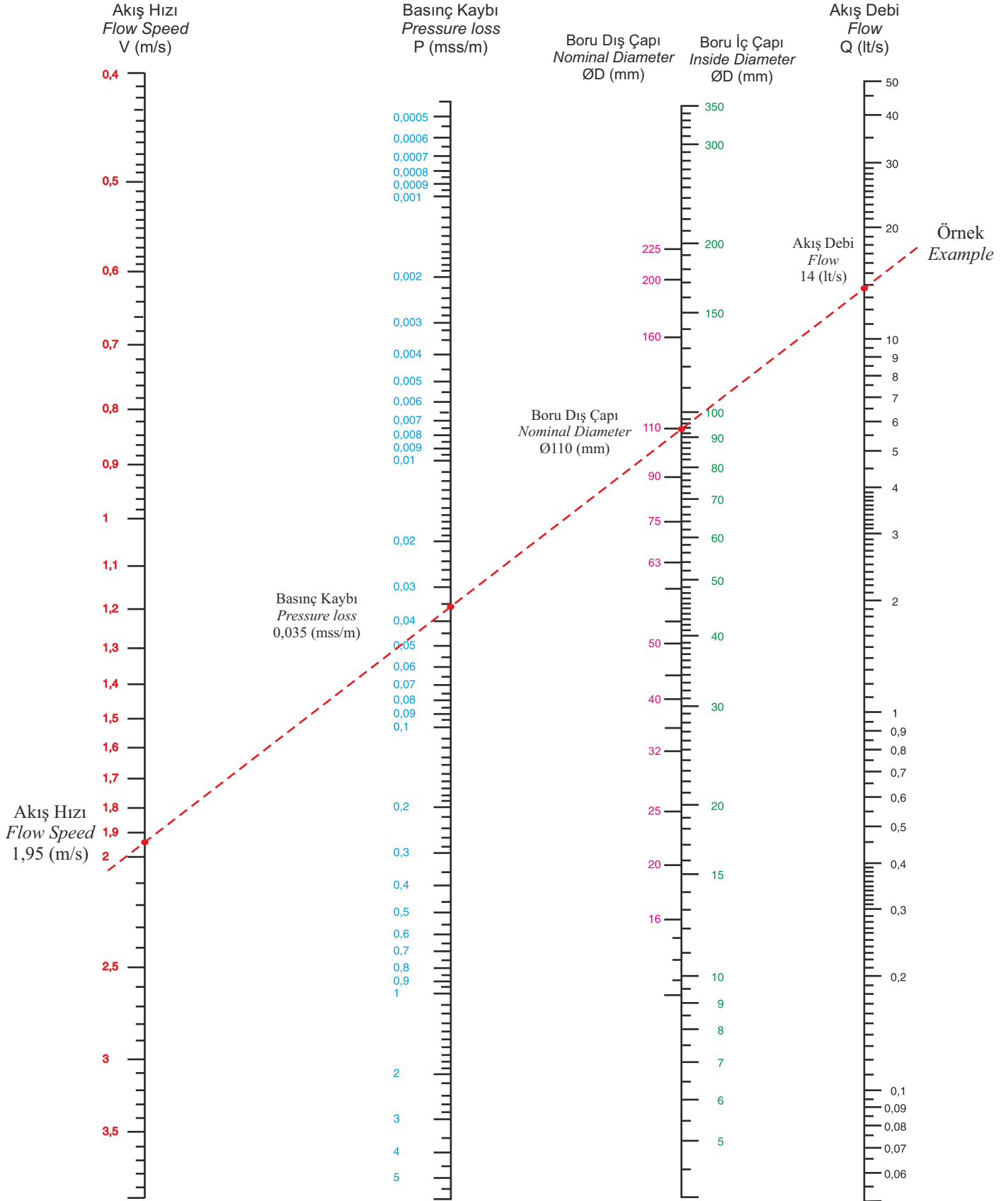

Bilinen iki değer yardımıyla doğru çizilerek istenen diğer değerlere ulaşılabilir.
Joining the two values on lines and extending the line henceforth will give the desired values.